

Einstecken und Profildrehen, Vollradius

Vollradiusnuten, CNC-Konturdrehen. Universelle Schneidengeometrie für die Bearbeitung eines breiten Materialspektrums.

Grooving and Profiling, Full Radius

Full radius, CNC profiling. With general cutting edge geometry for a wide variety of workpiece materials.

Schnittwerte (Start) // Cutting parameters (start)

f	Vc
0,02 mm/U	Seite/Page 429

Passende Klemhalter auf Seite // Suitable toolholders on page 257, 258, 259

SP
HM

R

○

Legende
Legend 272

Scan QR-Code Oder besuchen Sie // Or Visit www.simtek.info/cp/1117



Abbildung zeigt / Drawing shows: TK2.G.200.100.060 VS R



w ±0,02 mm	R mm	tmax mm	Artikelnummer Part number	Webcode www.simtek.com/webcode	Unsere erste Wahl Our first choice		S mm	Connectcode www.simtek.com/ccode
					P	K M N S		
1,0	0,5	3,0	TK2.G.100.050.030 VS R/L	R AYH0 L AYHZ	X808	X408	3,87	R TK2.G.R.04 L TK2.G.L.04
1,2	0,6	3,6	TK2.G.120.060.036 VS R/L	R AYHY L AYHX	X808	X408	3,92	R TK2.G.R.04 L TK2.G.L.04
1,6	0,8	4,8	TK2.G.160.080.048 VS R/L	R AYHV L AYHW	X808	X408	3,92	R TK2.G.R.04 L TK2.G.L.04
2,0	1,0	6,0	TK2.G.200.100.060 VS R/L	R AYHT L AYHU	X808	X408	3,92	R TK2.G.R.04 L TK2.G.L.04

Bestellbeispiel // Order example: **TK2.G.100.050.030 VS R X808** (R = Rechte Ausführung // Right hand version, X808 = Schneidstoff // Grade)

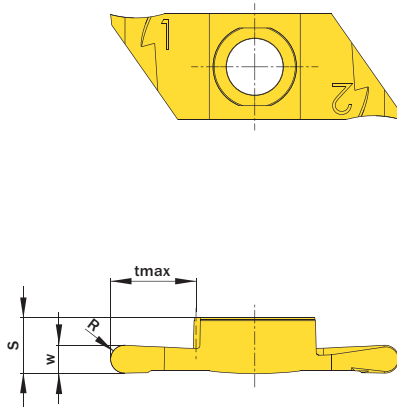
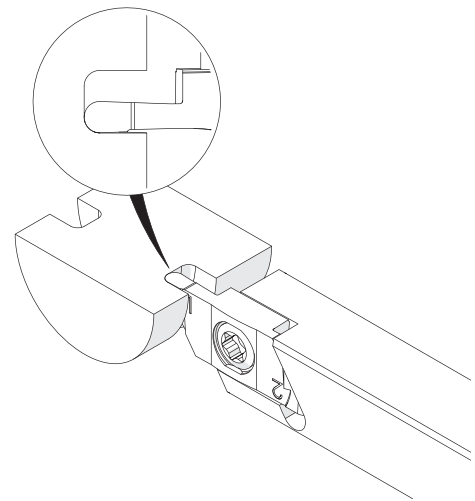
simturn AX
simturn DX
simturn PX
simturn H2
simturn K2
simturn C4
simturn GX
simturn E3
simturn E12
simturn FX
simturn Decolletage
simturn OA
Index