

Kleinteilebearbeitung // Small Part Machining
 simturn AX > Trägerwerkzeug // Toolholder



Klemmhalter, Innenbearbeitung, Rundschaft, „ME“

Rundschaft aus Hartmetall, besonders geeignet zur Erhöhung der möglichen Auskragung mit unserem neuen ME-Spannprinzip. Das ME-Spannsystem bietet kraftschlüssiges Spannen und dadurch optimale Präzision und Stabilität. Vier Kühlmittelzufuhrarten je nach Bedarf einstellbar.

Toolholder, Internal Applications, Round Shank „ME“

Carbide round shank, suitable for extending the overall tool reach equipped with our brand new ME-clamping system. The ME-system provides force-fitted clamping along with higher precision and stability. Four different types of through coolant supply can be realized as required.

Anzugsmoment (Schraube) // Tightening torque (screw)

15,0 Nm - 25,0 Nm

Bitte Hinweise im Anhang beachten // Please read add. notes

MASTER (Seite/Page 137), T02 (Seite/Page 138)

Scan QR-Code Oder besuchen Sie // Or Visit www.simtek.info/cp/1193

Legende Legend 139



Entdecken Sie unsere simturn AX Halter „ME“. Discover our simturn AX toolholder „ME“.

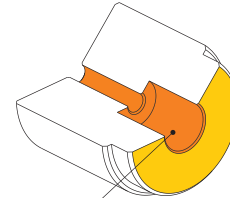
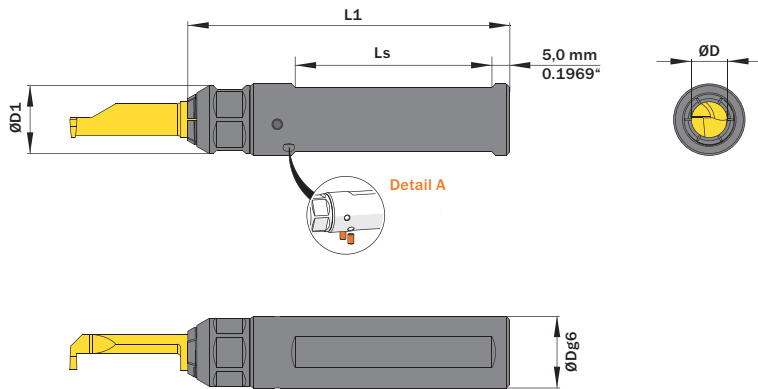

- Hauptsächlich geeignet für diese Flächen
Mainly designed for these surfaces
- Je nach Schneidplatte ebenfalls möglich
Also possible depending on insert type

Abbildung zeigt / Drawing shows: A10.0020.ME ST T

ØD	ØDg6	Artikelnummer Part number	Webcode www.simtek.com/webcode	ØD1	L1	Ls	Standard Mutter Standard screw nut	Connectcode www.simtek.com/code
mm	mm			mm	mm	mm		

Fortgesetzte Tabelle
Continued Table

Verwandte Werkzeuge finden Sie auch auf der vorhergehenden Seite!
Related items can be found on the previous page as well!

10,0	19,05	A10.0.750.ME ST T	AZUE	19,0	110,0	75,0	A00.K.19.15.138	A10.L A10.R A10T	Inch
10,0	20,0	A10.0020.ME ST T	AY7W	19,0	90,0	55,0	A00.K.19.15.138	A10.L A10.R A10T	
10,0	25,0	A10.0025.ME ST T	AY7X	19,0	110,0	75,0	A00.K.19.15.138	A10.L A10.R A10T	
10,0	25,4	A10.1.000.ME ST T	A015	19,0	110,0	75,0	A00.K.19.15.138	A10.L A10.R A10T	Inch

Bestellbeispiel // Order example: **A10.0020.ME ST T**

Detail A | 1 Halter - 4 Kühlmittelzufuhrarten // 1 Toolholder - 4 types of coolant supply

