

Klemmhalter, Innenbearbeitung, Rundschaft, „ME“

Rundschaft aus Hartmetall, besonders geeignet zur Erhöhung der möglichen Auskragung mit unserem neuen ME-Spannprinzip. Das ME-Spannsystem bietet kraftschlüssiges Spannen und dadurch optimale Präzision und Stabilität. Vier Kühlmittelzufuhrarten je nach Bedarf einstellbar.

Toolholder, Internal Applications, Round Shank „ME“

Carbide round shank, suitable for extending the overall tool reach equipped with our brand new ME-clamping system. The ME-system provides force-fitted clamping along with higher precision and stability. Four different types of through coolant supply can be realized as required.

Anzugsmoment (Schraube) // Tightening torque (screw)

15,0 Nm - 25,0 Nm

Bitte Hinweise im Anhang beachten // Please read add. notes

MASTER (Seite/Page 137), T02 (Seite/Page 138)

Scan QR-Code Oder besuchen Sie // Or Visit www.simtek.info/cp/1195

Legende Legend **139**



Entdecken Sie unsere simturn AX Halter „ME“. Discover our simturn AX toolholder „ME“.

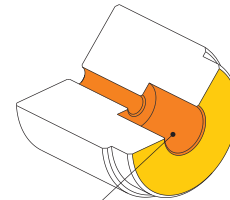
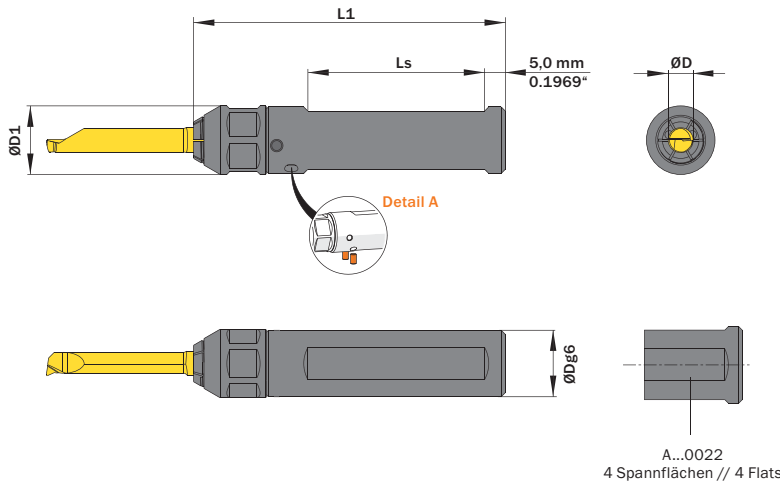

- **Hauptsächlich geeignet für diese Flächen**
Mainly designed for these surfaces
- **Je nach Schneidplatte ebenfalls möglich**
Also possible depending on insert type

Abbildung zeigt / Drawing shows: A06.0016.ME ST T

ØD	ØDg6	Artikelnummer Part number	Webcode www.simtek.com/webcode	ØD1	L1	Ls	Standard Mutter Standard screw nut	Connectcode www.simtek.com/ccode
mm	mm			mm	mm	mm		

Fortgesetzte Tabelle Continued Table **Verwandte Werkzeuge finden Sie auch auf der vorhergehenden Seite!**
Related items can be found on the previous page as well!

6,0	12,0	A06.0012.ME ST T	AZJ5	16,5	70,0	37,5	A00.K.16.12.108	A06.L A06.R A06T
6,0	12,7	A06.0.500.ME ST T	A0YK	16,5	70,0	37,5	A00.K.16.12.108	A06.L A06.R A06T <small>inch</small>
6,0	15,875	A06.0.625.ME ST T	AZN4	16,5	75,0	42,5	A00.K.16.12.108	A06.L A06.R A06T <small>inch</small>
6,0	16,0	A06.0016.ME ST T	AY7M	16,5	75,0	42,5	A00.K.16.12.108	A06.L A06.R A06T
6,0	19,05	A06.0.750.ME ST T	AZNK	16,5	110,0	77,5	A00.K.16.12.108	A06.L A06.R A06T <small>inch</small>
6,0	20,0	A06.0020.ME ST T	AY7N	16,5	90,0	57,5	A00.K.16.12.108	A06.L A06.R A06T
6,0	22,0	A06.0022.ME ST T	AZJ6	16,5	110,0	77,5	A00.K.16.12.108	A06.L A06.R A06T
6,0	23,0	A06.0023.ME ST T	AZJ7	16,5	110,0	77,5	A00.K.16.12.108	A06.L A06.R A06T
6,0	25,0	A06.0025.ME ST T	AY7P	16,5	110,0	77,5	A00.K.16.12.108	A06.L A06.R A06T
6,0	25,4	A06.1.000.ME ST T	A0ZJ	16,5	110,0	77,5	A00.K.16.12.108	A06.L A06.R A06T <small>inch</small>

Verwandte Werkzeuge finden Sie auch auf der folgenden Seite!
Related items can be found on the following page as well!

Fortgesetzte Tabelle Continued Table

Bestellbeispiel // Order example: **A06.0016.ME ST T**

Detail A | 1 Halter – 4 Kühlmittelzufuhrarten // 1 Toolholder – 4 types of coolant supply

