

Halbzeuge

Halbzeuge für komponenten- und kundenspezifische Formen.

Semi-Finished Inserts

Semi-finished-insert for component- and customer-specific forms.



Abbildung zeigt / Drawing shows: CK2.A.0390.00 M

Schnittwerte (Start) // Cutting parameters (start) Vc
Seite/Page 727

Passende Klemmhalter auf Seite // Suitable toolholders on page
741, 742, 743, 744, 745, 746, 747

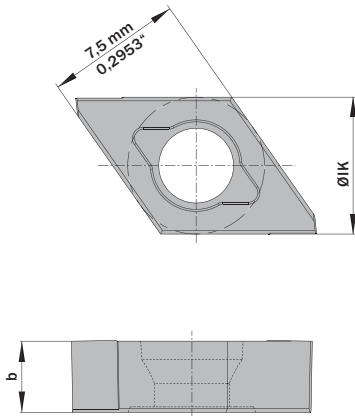

SP Legende
HM Legend **764**

Scan QR-Code Oder besuchen Sie // Or Visit
www.simtek.info/cp/1095

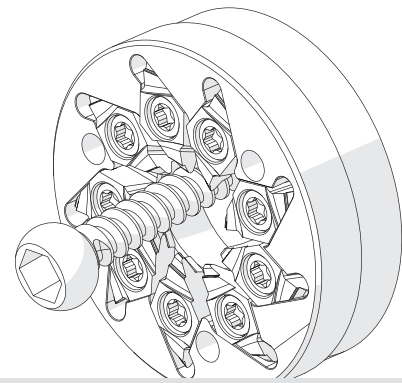

Illustration zeigt beispielhafte Anwendungsmöglichkeit mit ähnlichem Werkzeug.
Image shows exemplary application possibility with similar tool.

b	Artikelnummer Part number	Webcode www.simtek.com/webcode	ØIK	Connectcode www.simtek.com/code
mm			mm	
3,9	CK2.A.0390.00 M	AXYJ	7,5	CK2.L.4.0
6,3	CK2.A.0630.00 M	AXYK	7,5	CK2.L.4.0

Bestellbeispiel // Order example: **CK2.A.0390.00 M GF25** (GF25 = Schneidstoff // Grade)