

# Gewindewirbelkopf „WTO“

Für WTO-Aggregat.

# Thread Whirling Head „WTO“

For WTO whirling units.

Anzugsmoment (Schraube) // Tightening torque (screw)

**3,5 Nm**



Legende  
Legend **764**



Scan  
QR-Code

Oder besuchen Sie // Or Visit  
[www.simtek.info/cp/1090](http://www.simtek.info/cp/1090)



Abbildung zeigt / Drawing shows: CK2.A.1242.09 W

ØDS	Anzahl Plattensitze Number of insert seats	Artikelnummer Part number	Webcode www.simtek.com/webcode	ØDa	ØDk	I	L	Aggregat Whirling units	Schraube Screw	Schraubenschlüssel Screw driver	Connectcode www.simtek.com/code
mm				mm	mm	mm	mm				
11,4	9	<b>CK2.A.1242.09 W</b>	AXYB	32,0	42,0	6,7	18,7	TN762004	ATKM	T10F	CK2.L.4.0

Bestellbeispiel // Order example: **CK2.A.1242.09 W**

Um Spanproblem auf Grund des geringen Schneidkreises zu vermeiden, empfehlen wir bei diesem Werkzeug mit einem hohen Kühlmitteldruck zu arbeiten.  
In order to prevent chip problems due to the small cutting diameter, we recommend to use these tools together with a high coolant pressure.

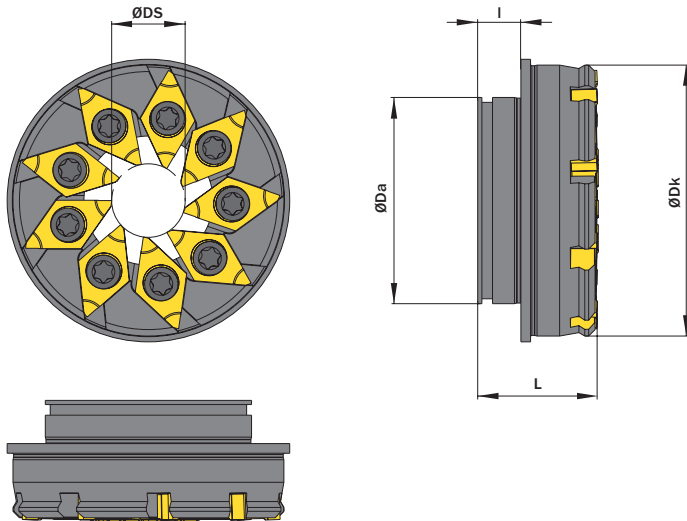
Eine Umschlüsselungsliste von **Webcode zu Schrauben bzw. Spannmuttern** finden Sie auf Seite **766**.  
A conversion list from **webcode to screws as well as standard screw nuts** can be found on page **766**.