

Metrisches ISO-Gewindefräsen, Vollprofil

Fräsen von metrischen ISO-Gewinden, Vollprofil.

Thread milling, metric ISO-Thread, full profile

Thread milling of metric ISO-thread, full profile.

Schnittwerte (Start) // Cutting parameters (start)

fzm 0,02 mm	hmax 0,03 mm	Vc Seite/Page 638
-----------------------	------------------------	-----------------------------

Passende Klemmhalter auf Seite // Suitable toolholders on page
508, 509, 510, 511, 512

Vergleichbare Werkzeuge auf Seite // Similar tools on page
467

Bitte Hinweise im Anhang beachten // Please read add. notes
ALL (Seite/Page 645), H06 (Seite/Page 648)



SP Legende
HM Legend

650



Scan
QR-Code

Oder besuchen Sie // Or Visit
www.simtek.info/cp/1087

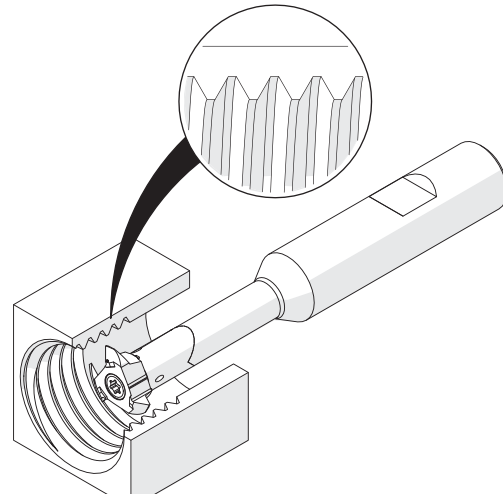
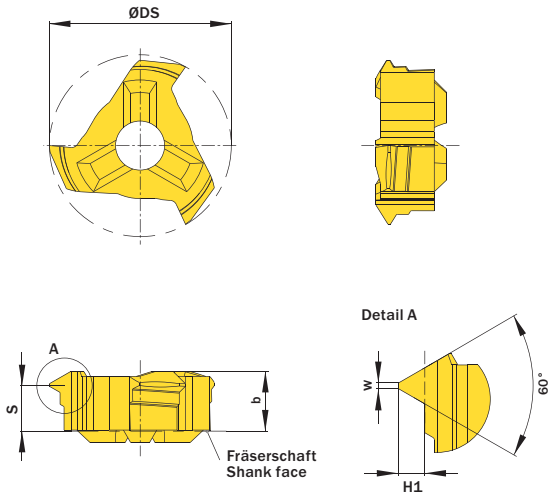

Illustration zeigt beispielhafte Anwendungsmöglichkeit mit ähnlichem Werkzeug.
Image shows exemplary application possibility with similar tool.

Abbildung zeigt / Drawing shows: S14.0815.02 M

Ab Gewindegröße As of thread size	Ab Gewindennenn- messer // As of nominal thread diameter	H1	Steigung (von) Pitch (as of)	Artikelnummer Part number	Webcode www.simtek.com/webcode	Unsere erste Wahl Our first choice				Anzahl Schneiden Number of cutting edges	b	ØDS	S	w	Connectcode www.simtek.com/code	upd
						P	M	K	N							
M16	15,64	0,54	1,0	S14.0510.02 M	AXXY	X800	GT42	3	4,5	13,7	3,6	0,13	SD08.0 SD09.5	upd		
M18	17,57	0,81	1,5	S14.0815.02 M	AXXZ	X800	GT42	3	4,5	13,7	3,5	0,19	SD08.0 SD09.5	upd		
M20	18,65	0,95	1,75	S14.0917.02 M	AXX0	X800	GT42	3	4,5	13,7	3,4	0,21	SD08.0 SD09.5	upd		
M20	19,8	1,08	2,0	S14.1020.02 M	AXX1	X800	GT42	3	4,5	13,7	3,3	0,25	SD08.0 SD09.5	upd		
M22	20,9	1,35	2,5	S14.1325.02 M	AXX2	X800	GT42	3	4,5	13,7	3,1	0,31	SD08.0 SD09.5	upd		
M22	21,95	1,62	3,0	S14.1630.02 M	AXX3	X800	GT42	3	4,5	13,7	2,9	0,37	SD08.0 SD09.5	upd		

Bestellbeispiel // Order example: **S14.1325.02 M X800** (X800 = Schneidstoff // Grade)