

## Einstecken und Profildrehen

CNC-Konturdrehen, universelle Schneidengeometrie für die Bearbeitung eines breiten Materialspektrums.

## Grooving and Profiling

CNC profiling, with general cutting edge geometry for a wide variety of workpiece materials.

Schnittwerte (Start) // Cutting parameters (start)

f	Vc
0,02 mm/U	Seite/Page 429

Passende Klemmhalter auf Seite // Suitable toolholders on page 277

SP

HM

R

Scan QR-Code

Legende Legend **289**

Oder besuchen Sie // Or Visit [www.simtek.info/cp/1080](http://www.simtek.info/cp/1080)

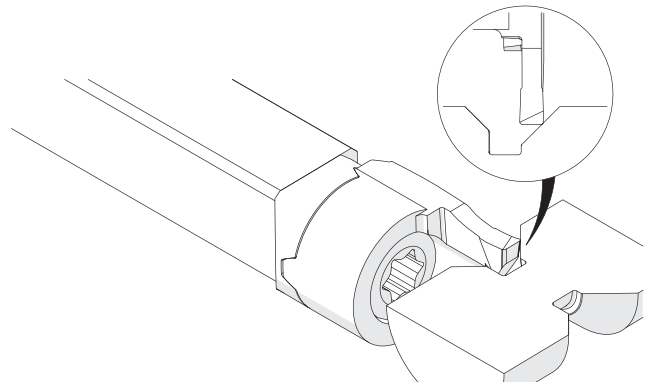
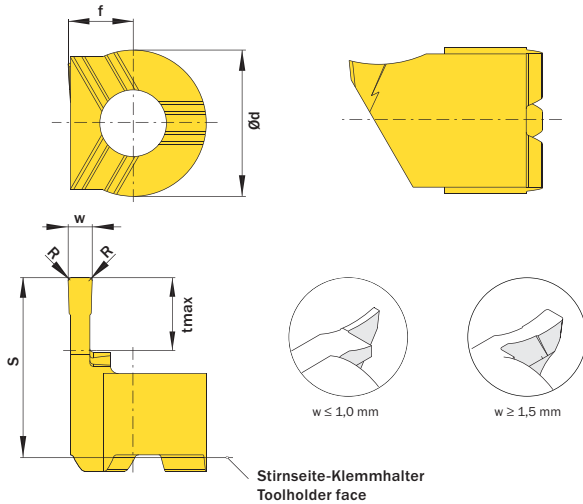

Illustration zeigt beispielhafte Anwendungsmöglichkeit mit ähnlichem Werkzeug. Image shows exemplary application possibility with similar tool.

Abbildung zeigt / Drawing shows: TC4.150.020.055 NS R

w	R	tmax	Artikelnummer Part number	Webcode www.simtek.com/webcode	Unsere erste Wahl Our first choice	Ød	f	S	Connectcode www.simtek.com/ccode
mm	mm	mm			P K M N S	mm	mm	mm	
<b>▼ w = 0,5 mm</b>									
0,5	0,05	2,5	<b>TC4.050.005.025 NS R/L</b>	R AXSF L AXSG	X808 X408	9,0	4,0	11,0	R TC4.R L TC4.L
<b>▼ w = 0,75 mm</b>									
0,75	0,05	3,75	<b>TC4.075.005.038 NS R/L</b>	R AXSB L AXSC	X808 X408	9,0	4,0	11,0	R TC4.R L TC4.L
<b>▼ w = 1,0 mm</b>									
1,0	0,05	5,5	<b>TC4.100.005.055 NS R/L</b>	R AXQ3 L AXQ4	X808 X408	9,0	4,0	11,0	R TC4.R L TC4.L
<b>▼ w = 1,5 mm</b>									
1,5	0,2	5,5	<b>TC4.150.020.055 NS R/L</b>	R AXQX L AXQY	X808 X408	9,0	4,0	11,0	R TC4.R L TC4.L

Bestellbeispiel // Order example: **TC4.100.005.055 NS R X808** (R = Rechte Ausführung // Right hand version, X808 = Schneidstoff // Grade)