

Nutenstechen

Gerade Nutformen, spezielle Schneidengeometrie für die Bearbeitung von Messing, Kupferlegierungen und anderen kurzspanenden Werkstoffen.

Grooving

General grooving, with special cutting edge geometry for brass, copper-based alloys and short-chipping materials.

Schnittwerte (Start) // Cutting parameters (start)	
f	Vc
0,02 mm/U	Seite/Page 429

Passende Klemmhalter auf Seite // Suitable toolholders on page 277

SP
HM

R

CU

Legende
Legend **289**

Scan QR-Code Oder besuchen Sie // Or Visit www.simtek.info/cp/1078

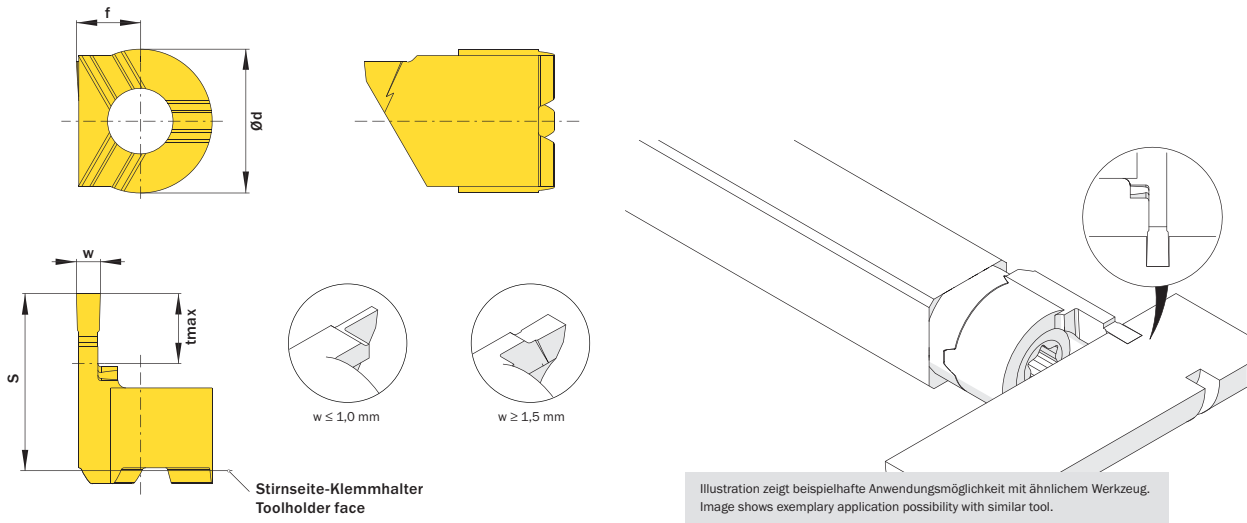

Abbildung zeigt / Drawing shows: TC4.150.000.055 GU R

w	tmax	Artikelnummer Part number	Webcode www.simtek.com/webcode	Unsere erste Wahl Our first choice	Ød	f	S	Connectcode www.simtek.com/ccode	
mm	mm			P K M N S	mm	mm	mm		
▼ w = 0,5 mm									
0,5	2,5	TC4.050.000.025 GU R/L	R AXP5 L AXP6	X808 X408	9,0	4,0	11,0	R TC4.R L TC4.L	
▼ w = 0,75 mm									
0,75	3,75	TC4.075.000.038 GU R/L	R AXP1 L AXP2	X808 X408	9,0	4,0	11,0	R TC4.R L TC4.L	
▼ w = 1,0 mm									
1,0	5,5	TC4.100.000.055 GU R/L	R AXPT L AXPU	X808 X408	9,0	4,0	11,0	R TC4.R L TC4.L	
▼ w = 1,5 mm									
1,5	5,5	TC4.150.000.055 GU R/L	R AXPK L AXPM	X808 X408	9,0	4,0	11,0	R TC4.R L TC4.L	

Bestellbeispiel // Order example: **TC4.150.000.055 GU R X808** (R = Rechte Ausführung // Right hand version, X808 = Schneidstoff // Grade)

simturn AX
simturn DX
simturn PX
simturn H2
simturn K2
simturn C4
simturn GX
simturn E3
simturn E12
simturn FX
simturn Decolletage
simturn OA
Index