

# Nutenstechen

Gerade Nutformen, universelle Schneidengeometrie für die Bearbeitung eines breiten Materialspektrums.

## Grooving

General grooving, with general cutting edge geometry for a wide variety of workpiece materials.

Schnittwerte (Start) // Cutting parameters (start)

f	Vc
0,02 mm/U	Seite/Page 429

Passende Klemmhalter auf Seite // Suitable toolholders on page 277

SP HM R Legende Legend 289  
 Scan QR-Code Oder besuchen Sie // Or Visit [www.simtek.info/cp/1081](http://www.simtek.info/cp/1081)

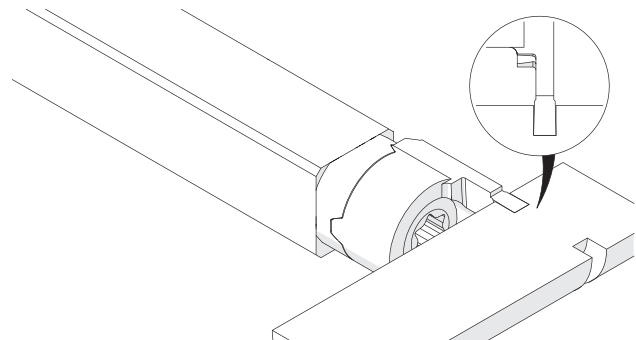
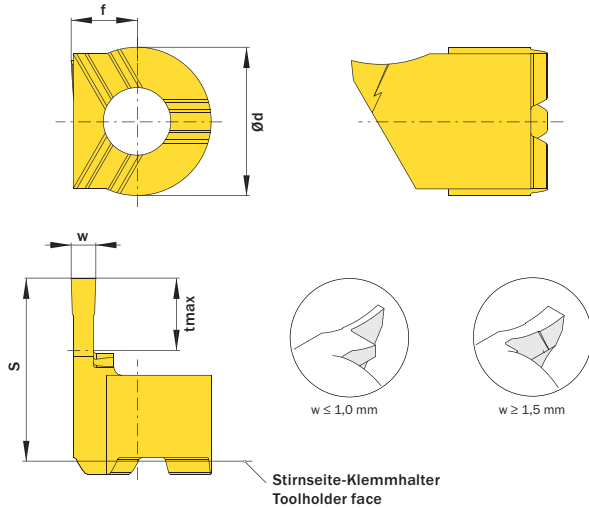

Illustration zeigt beispielhafte Anwendungsmöglichkeit mit ähnlichem Werkzeug. Image shows exemplary application possibility with similar tool.

Abbildung zeigt / Drawing shows: TC4.150.000.055 GS R

w ±0,015 mm	tmax mm	Artikelnummer Part number	Webcode www.simtek.com/webcode	Unsere erste Wahl Our first choice	Ød mm	f mm	S mm	Connectcode www.simtek.com/code	
▼ w = 0,5 mm									
0,5	2,5	TC4.050.000.025 GS R/L	R AXN9 L AXPA X808 X408		9,0	4,0	11,0	R TC4.R L TC4.L	
▼ w = 0,75 mm									
0,75	3,75	TC4.075.000.038 GS R/L	R AXN5 L AXN6 X808 X408		9,0	4,0	11,0	R TC4.R L TC4.L	
▼ w = 1,0 mm									
1,0	5,5	TC4.100.000.055 GS R/L	R AXNX L AXNY X808 X408		9,0	4,0	11,0	R TC4.R L TC4.L	
▼ w = 1,5 mm									
1,5	5,5	TC4.150.000.055 GS R/L	R AXNQ L AXNS X808 X408		9,0	4,0	11,0	R TC4.R L TC4.L	

Bestellbeispiel // Order example: **TC4.100.000.055 GS R X808** (R = Rechte Ausführung // Right hand version, X808 = Schneidstoff // Grade)