

Gewindedrehen, Metr. ISO, Außen, Teilprofil

Mehrbereichswerkzeuge für verschiedene Steigungen.

Threading, Metr. ISO, External, Partial Profile

Multi-purpose tools, usable for different pitches.

Schnittwerte (Start) // Cutting parameters (start)

f	Vc
0,02 mm/U	Seite/Page 429

Passende Klemmhalter auf Seite // Suitable toolholders on page 277

Empf. Zustellungsart // Recom. infeed method
Flankenzustellung // Flank infeed (Seite/Page 433)

Bitte Hinweise im Anhang beachten // Please read add. notes
T01 (Seite/Page 288)

SP

HM

R

Legende
Legend **289**

Scan QR-Code Oder besuchen Sie // Or Visit www.simtek.info/cp/1084

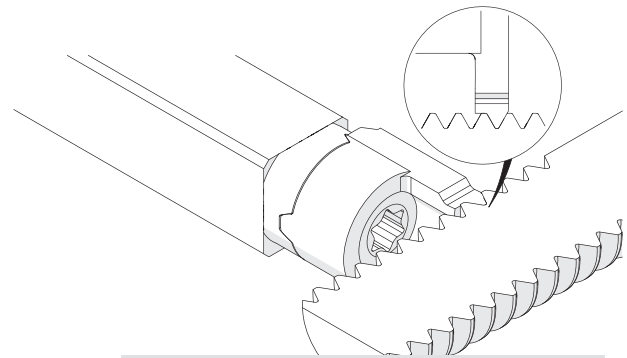
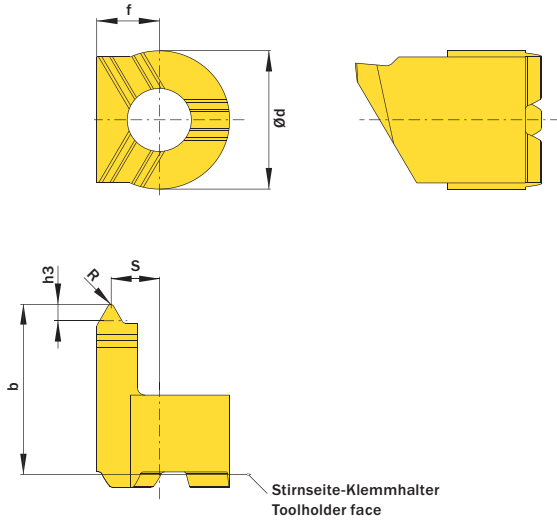

Illustration zeigt beispielhafte Anwendungsmöglichkeit mit ähnlichem Werkzeug.
Image shows exemplary application possibility with similar tool.

Abbildung zeigt / Drawing shows: TC4.M150.01 EMU R

Steigung (von) Pitch (as of)	Steigung (bis) Pitch (up to)	Artikelnummer Part number	Webcode www.simtek.com/webcode	Unsere erste Wahl Our first choice				b	Ød	f	h3	R	S	Connectcode www.simtek.com/code		
				P	K	M	S							R	L	TC4.L
0,25	0,45	TC4.M025.01 EMU R/L	R AYQQ L AYQP	X808	X408	11,0	9,0	4,0	0,15	0,04	3,6	R	TC4.R	L	TC4.L	
0,4	0,6	TC4.M040.01 EMU R/L	R AXMF L AXMG	X808	X408	11,0	9,0	4,0	0,25	0,06	3,5	R	TC4.R	L	TC4.L	
0,5	0,75	TC4.M050.01 EMU R/L	R AXMB L AXMC	X808	X408	11,0	9,0	4,0	0,31	0,07	3,4	R	TC4.R	L	TC4.L	
0,7	1,0	TC4.M070.01 EMU R/L	R AXK7 L AXK8	X808	X408	11,0	9,0	4,0	0,43	0,1	3,3	R	TC4.R	L	TC4.L	
0,8	1,25	TC4.M080.01 EMU R/L	R AXK5 L AXK6	X808	X408	11,0	9,0	4,0	0,49	0,12	3,3	R	TC4.R	L	TC4.L	
1,0	1,5	TC4.M100.01 EMU R/L	R AXK3 L AXK4	X808	X408	11,0	9,0	4,0	0,61	0,14	3,2	R	TC4.R	L	TC4.L	
1,25	1,75	TC4.M125.01 EMU R/L	R AXK1 L AXK2	X808	X408	11,0	9,0	4,0	0,77	0,18	3,1	R	TC4.R	L	TC4.L	
1,5	2,0	TC4.M150.01 EMU R/L	R AXKZ L AXK0	X808	X408	11,0	9,0	4,0	0,92	0,22	3,0	R	TC4.R	L	TC4.L	
1,75	2,5	TC4.M175.01 EMU R/L	R AYUV L AYUW	X808	X408	11,0	9,0	4,0	1,07	0,25	2,9	R	TC4.R	L	TC4.L	
2,0	2,5	TC4.M200.01 EMU R/L	R AXKX L AXKY	X808	X408	11,0	9,0	4,0	1,23	0,29	2,8	R	TC4.R	L	TC4.L	

Bestellbeispiel // Order example: **TC4.M070.01 EMU R X808** (R = Rechte Ausführung // Right hand version, X808 = Schneidstoff // Grade)

Bitte beachten Sie die zusätzlichen Hinweise im Infobereich rechts oben.

Please read the additional notes mentioned in the information area on the top right corner of this page.

simturn AX
simturn DX
simturn PX
simturn H2
simturn K2
simturn C4
simturn GX
simturn E3
simturn E12
simturn FX
simturn Decolletage
simturn OA
Index