

Gewindedrehen, Metr. ISO, Außen, Teilprofil

Mehrbereichswerkzeuge für verschiedene Steigungen.

Threading, Metr. ISO, External, Partial Profile

Multi-purpose tools, usable for different pitches.

Schnittwerte (Start) // Cutting parameters (start)

f	Vc
0,02 mm/U	Seite/Page 429

Passende Klemmhalter auf Seite // Suitable toolholders on page 277

Empf. Zustellungsart // Recom. infeed method
Flankenzustellung // Flank infeed (Seite/Page 433)

Bitte Hinweise im Anhang beachten // Please read add. notes
T01 (Seite/Page 288)

SP
HM

R

○

Legende
Legend **289**

Scan
QR-Code

Oder besuchen Sie // Or Visit
www.simtek.info/cp/1084

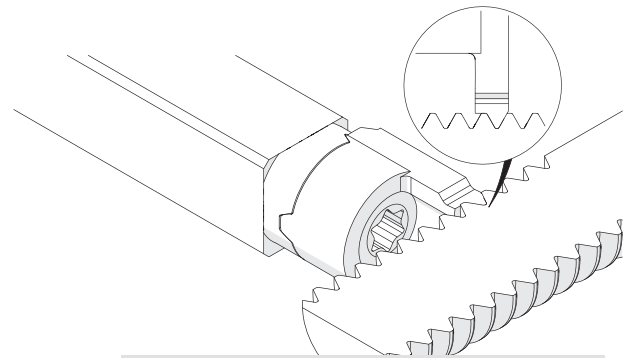
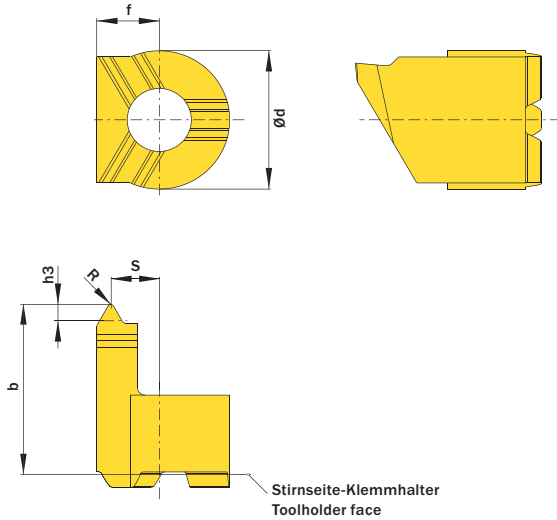

Illustration zeigt beispielhafte Anwendungsmöglichkeit mit ähnlichem Werkzeug.
Image shows exemplary application possibility with similar tool.

Abbildung zeigt / Drawing shows: TC4.M150.01 EMU R

Steigung (von) Pitch (as of)	Steigung (bis) Pitch (up to)	Artikelnummer Part number	Webcode www.simtek.com/webcode	Unsere erste Wahl Our first choice				b	Ød	f	h3	R	S	Connectcode www.simtek.com/ccode		
				P	K	M	S							R	L	TC4.L
0,25	0,45	TC4.M025.01 EMU R/L	R AYQQ L AYQP	X808	X408	11,0	9,0	4,0	0,15	0,04	3,6	R	TC4.R	L	TC4.L	
0,4	0,6	TC4.M040.01 EMU R/L	R AXMF L AXMG	X808	X408	11,0	9,0	4,0	0,25	0,06	3,5	R	TC4.R	L	TC4.L	
0,5	0,75	TC4.M050.01 EMU R/L	R AXMB L AXMC	X808	X408	11,0	9,0	4,0	0,31	0,07	3,4	R	TC4.R	L	TC4.L	
0,7	1,0	TC4.M070.01 EMU R/L	R AXK7 L AXK8	X808	X408	11,0	9,0	4,0	0,43	0,1	3,3	R	TC4.R	L	TC4.L	
0,8	1,25	TC4.M080.01 EMU R/L	R AXK5 L AXK6	X808	X408	11,0	9,0	4,0	0,49	0,12	3,3	R	TC4.R	L	TC4.L	
1,0	1,5	TC4.M100.01 EMU R/L	R AXK3 L AXK4	X808	X408	11,0	9,0	4,0	0,61	0,14	3,2	R	TC4.R	L	TC4.L	
1,25	1,75	TC4.M125.01 EMU R/L	R AXK1 L AXK2	X808	X408	11,0	9,0	4,0	0,77	0,18	3,1	R	TC4.R	L	TC4.L	
1,5	2,0	TC4.M150.01 EMU R/L	R AXKZ L AXK0	X808	X408	11,0	9,0	4,0	0,92	0,22	3,0	R	TC4.R	L	TC4.L	
1,75	2,5	TC4.M175.01 EMU R/L	R AYUV L AYUW	X808	X408	11,0	9,0	4,0	1,07	0,25	2,9	R	TC4.R	L	TC4.L	
2,0	2,5	TC4.M200.01 EMU R/L	R AXKX L AXKY	X808	X408	11,0	9,0	4,0	1,23	0,29	2,8	R	TC4.R	L	TC4.L	

Bestellbeispiel // Order example: **TC4.M070.01 EMU R X808** (R = Rechte Ausführung // Right hand version, X808 = Schneidstoff // Grade)

Bitte beachten Sie die zusätzlichen Hinweise im Infobereich rechts oben.

Please read the additional notes mentioned in the information area on the top right corner of this page.