

# Gewindedrehen, Metr. ISO, Außen, Teilprofil

Mehrbereichswerkzeuge für verschiedene Steigungen.

# Threading, Metr. ISO, External, Partial Profile

Multi-purpose tools, usable for different pitches.

Schnittwerte (Start) // Cutting parameters (start)

f	Vc
0,02 mm/U	Seite/Page 429

Passende Klemmhalter auf Seite // Suitable toolholders on page 277

Empf. Zustellungsart // Recom. infeed method  
**Flankenzustellung // Flank infeed (Seite/Page 433)**

Bitte Hinweise im Anhang beachten // Please read add. notes  
**T01 (Seite/Page 288)**





 Legende Legend **289**

Scan QR-Code Oder besuchen Sie // Or Visit [www.simtek.info/cp/1084](http://www.simtek.info/cp/1084)

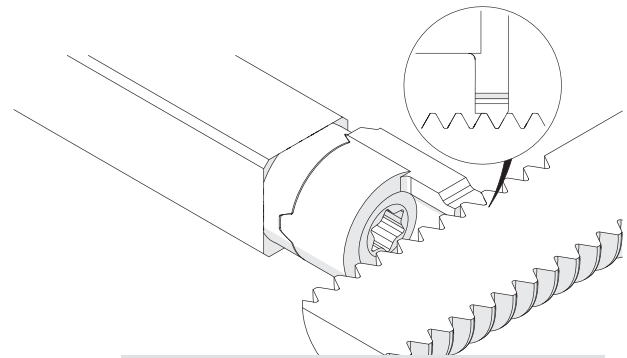
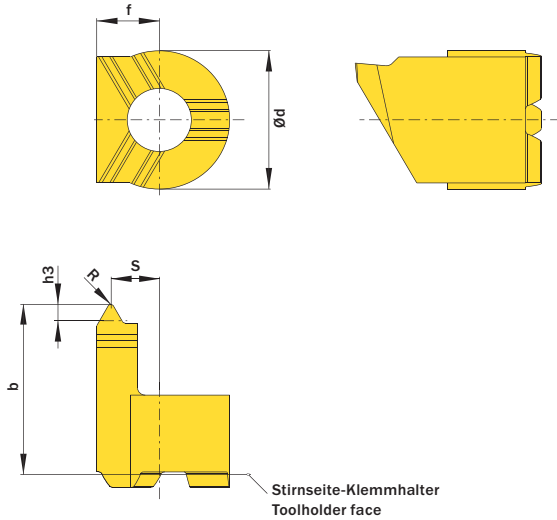

Illustration zeigt beispielhafte Anwendungsmöglichkeit mit ähnlichem Werkzeug. Image shows exemplary application possibility with similar tool.

Abbildung zeigt / Drawing shows: TC4.M150.01 EMU R

Steigung (von) Pitch (as of)	Steigung (bis) Pitch (up to)	Artikelnummer Part number	Webcode www.simtek.com/webcode	Unsere erste Wahl Our first choice				b	Ød	f	h3	R	S	Connectcode www.simtek.com/ccode		
				P	K	M	S							R	L	TC4.L
0,25	0,45	<b>TC4.M025.01 EMU R/L</b>	R AYQQ L AYQP	X808	X408	11,0	9,0	4,0	0,15	0,04	3,6	R	TC4.R	L	TC4.L	
0,4	0,6	<b>TC4.M040.01 EMU R/L</b>	R AXMF L AXMG	X808	X408	11,0	9,0	4,0	0,25	0,06	3,5	R	TC4.R	L	TC4.L	
0,5	0,75	<b>TC4.M050.01 EMU R/L</b>	R AXMB L AXMC	X808	X408	11,0	9,0	4,0	0,31	0,07	3,4	R	TC4.R	L	TC4.L	
0,7	1,0	<b>TC4.M070.01 EMU R/L</b>	R AXK7 L AXK8	X808	X408	11,0	9,0	4,0	0,43	0,1	3,3	R	TC4.R	L	TC4.L	
<b>0,8</b>	<b>1,25</b>	<b>TC4.M080.01 EMU R/L</b>	R <b>AXK5</b> L <b>AXK6</b>	<b>X808</b>	<b>X408</b>	<b>11,0</b>	<b>9,0</b>	<b>4,0</b>	<b>0,49</b>	<b>0,12</b>	<b>3,3</b>	R	TC4.R	L	TC4.L	
1,0	1,5	<b>TC4.M100.01 EMU R/L</b>	R AXK3 L AXK4	X808	X408	11,0	9,0	4,0	0,61	0,14	3,2	R	TC4.R	L	TC4.L	
1,25	1,75	<b>TC4.M125.01 EMU R/L</b>	R AXK1 L AXK2	X808	X408	11,0	9,0	4,0	0,77	0,18	3,1	R	TC4.R	L	TC4.L	
1,5	2,0	<b>TC4.M150.01 EMU R/L</b>	R AXKZ L AXK0	X808	X408	11,0	9,0	4,0	0,92	0,22	3,0	R	TC4.R	L	TC4.L	
1,75	2,5	<b>TC4.M175.01 EMU R/L</b>	R AYUV L AYUW	X808	X408	11,0	9,0	4,0	1,07	0,25	2,9	R	TC4.R	L	TC4.L	
2,0	2,5	<b>TC4.M200.01 EMU R/L</b>	R AXKX L AXKY	X808	X408	11,0	9,0	4,0	1,23	0,29	2,8	R	TC4.R	L	TC4.L	

Bestellbeispiel // Order example: **TC4.M070.01 EMU R X808** (R = Rechte Ausführung // Right hand version, X808 = Schneidstoff // Grade)

Bitte beachten Sie die zusätzlichen Hinweise im Infobereich rechts oben.

Please read the additional notes mentioned in the information area on the top right corner of this page.

simturn AX  
simturn DX  
simturn PX  
simturn H2  
simturn K2  
simturn C4  
simturn GX  
simturn E3  
simturn E12  
simturn FX  
simturn Decolletage  
simturn OA  
Index