

# Gewindedrehen, Metrisches ISO Vollprofil

Herstellung des vollständigen Gewindeprofils mit erforderlicher Tiefe.

# Threading, Metric ISO Full Profile

For a complete thread profile with correct depth.

Schnittwerte (Start) // Cutting parameters (start)
Anzahl Durchgänge // Number of passes <b>10 - 16</b>
Empf. Zustellungsart // Recom. infeed method <b>Flankenzustellung // Flank infeed (Seite/Page 433)</b>
Vc <b>Seite/Page 429</b>

Passende Klemmhalter auf Seite // Suitable toolholders on page  
**155, 156, 157, 161, 163, 164**

SP

HM

R

Legende  
Legend **213**

Scan  
QR-Code

Oder besuchen Sie // Or Visit  
[www.simtek.info/cp/823](http://www.simtek.info/cp/823)



Abbildung zeigt / Drawing shows: D11.0815.02 MR

HC	Steigung TP Pitch TP	Artikelnummer Part number	Webcode www.simtek.com/webcode	Unsere erste Wahl Our first choice	a	b	Ød	HA	HB	ØDmin (Min. Bohrung) ØDmin (min. bore)	f	S	Connectcode www.simtek.com/code	
mm	mm			P K M N S	mm	mm	mm	mm	mm	mm	mm	mm		
<b>▼ ØDmin (Min. Bohrung) // ØDmin (min. bore) = 9,0 mm</b>														
0,271	0,5	<b>D09.0205.02.09 MR/L</b>	R AWGT	L AWH6 X800 X400	8,6	3,65	6,2	0,325	0,054	9,0	5,5	3,25	D09	upd
0,541	1,0	<b>D09.0510.02.09 MR/L</b>	R AWGS	L AWH5 X800 X400	8,6	3,65	6,2	0,65	0,108	9,0	5,5	3,0	D09	upd
0,812	1,5	<b>D09.0815.02.09 MR/L</b>	R AWGQ	L AWH4 X800 X400	8,6	3,6	6,2	0,974	0,162	9,0	5,5	2,8	D09	upd
0,947	1,75	<b>D09.0917.02.09 MR/L</b>	R AWGP	L AWH3 X800 X400	8,6	3,6	6,2	1,137	0,189	9,0	5,5	2,7	D09	upd
1,083	2,0	<b>D09.1020.02.09 MR/L</b>	R AWGN	L AWH2 X800 X400	8,6	3,58	6,2	1,299	0,217	9,0	5,5	2,6	D09	upd
1,353	2,5	<b>D09.1325.02.09 MR/L</b>	R AWGM	L AWH1 X800 X400	8,6	3,56	6,2	1,624	0,271	9,0	5,5	2,5	D09	upd
1,624	3,0	<b>D09.1630.02.09 MR/L</b>	R AWGK	L AWH0 X800 X400	8,6	3,54	6,2	1,949	0,325	9,0	5,5	2,2	D09	upd
<b>▼ ØDmin (Min. Bohrung) // ØDmin (min. bore) = 10,0 mm</b>														
0,271	0,5	<b>D10.0205.02.10 MR/L</b>	R ANVA	L ADJC X800 X400	9,3	3,8	7,0	0,325	0,054	10,0	5,8	3,4	D10	upd
0,541	1,0	<b>D10.0510.02.10 MR/L</b>	R ANP1	L ADAV X800 X400	9,3	4,0	7,0	0,65	0,108	10,0	5,8	3,2	D10	upd
0,812	1,5	<b>D10.0815.02.10 MR/L</b>	R AM2E	L AA2U X800 X400	9,3	3,9	7,0	0,974	0,162	10,0	5,8	3,0	D10	upd
0,947	1,75	<b>D10.0917.02.10 MR/L</b>	R AD6Z	L ABYB X800 X400	9,3	3,9	7,0	1,137	0,189	10,0	5,8	2,9	D10	upd
1,083	2,0	<b>D10.1020.02.10 MR/L</b>	R AADQ	L AKFM X800 X400	9,3	3,9	7,0	1,299	0,217	10,0	5,8	2,75	D10	upd
1,353	2,5	<b>D10.1325.02.10 MR/L</b>	R AAG5	L AMY3 X800 X400	9,3	3,8	7,0	1,624	0,271	10,0	5,8	2,5	D10	upd
1,624	3,0	<b>D10.1630.02.10 MR/L</b>	R AJXD	L AKWA X800 X400	9,3	3,8	7,0	1,949	0,325	10,0	5,8	2,45	D10	upd
<b>▼ ØDmin (Min. Bohrung) // ØDmin (min. bore) = 11,0 mm</b>														
0,541	1,0	<b>D11.0510.02 MR/L</b>	R AJ3B	L AF7P X800 X400	10,7	4,3	8,0	0,65	0,108	11,0	6,7	3,6	D11	upd
0,812	1,5	<b>D11.0815.02 MR/L</b>	R AESU	L APF7 X800 X400	10,7	4,3	8,0	0,974	0,162	11,0	6,7	3,3	D11	upd
1,083	2,0	<b>D11.1020.02 MR/L</b>	R AF4G	L ACVY X800 X400	10,7	4,3	8,0	1,299	0,217	11,0	6,7	2,9	D11	upd
1,353	2,5	<b>D11.1325.02 MR/L</b>	R AN9M	L ACTN X800 X400	10,7	4,3	8,0	1,624	0,271	11,0	6,7	2,95	D11	upd
1,624	3,0	<b>D11.1630.02 MR/L</b>	R AKVC	L AJZG X800 X400	10,7	4,3	8,0	1,949	0,325	11,0	6,7	2,9	D11	upd

Verwandte Werkzeuge finden Sie auch auf der folgenden Seite!  
Related Items can be found on the following page as well!

Fortgesetzte Tabelle  
Continued Table

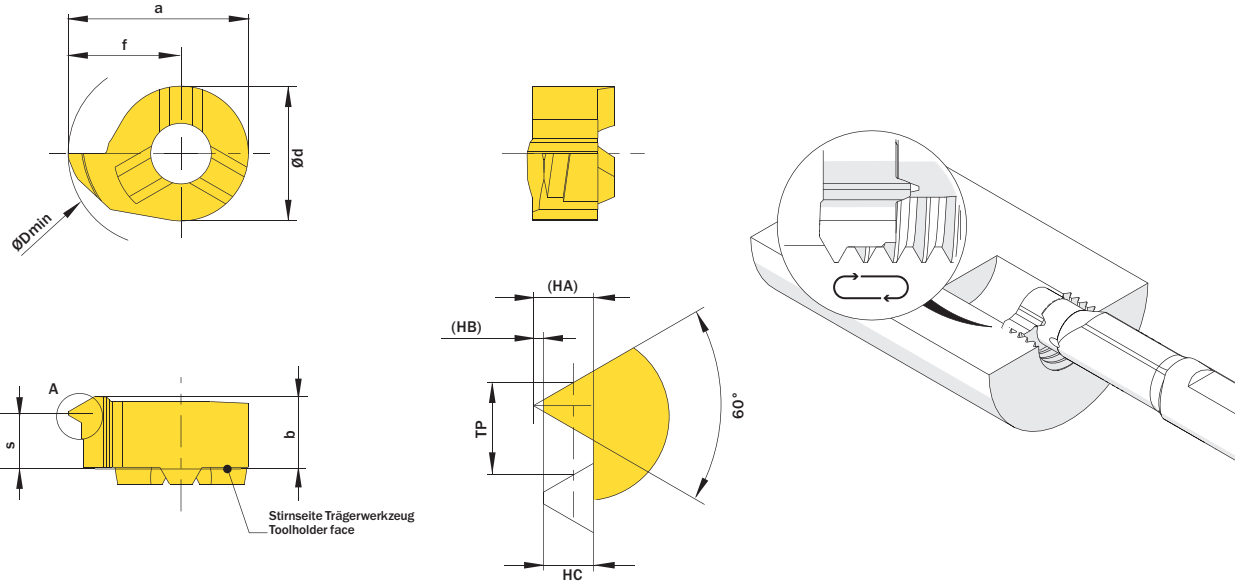
Bestellbeispiel // Order example: **D11.1020.02 MR X800** (R = Rechte Ausführung // Right hand version, X800 = Schneidstoff // Grade)