

Gewindedrehen, Metrisches ISO Vollprofil

Herstellung des vollständigen Gewindeprofils mit erforderlicher Tiefe.

Threading, Metric ISO Full Profile

For a complete thread profile with correct depth.

Schnittwerte (Start) // Cutting parameters (start)
Anzahl Durchgänge // Number of passes 10 - 16
Empf. Zustellungsart // Recom. infeed method Modifizierte einseitige Flankenzustellung // Modified one-sided flank infeed (Seite/Page 447)
Vc Seite/Page 442

Passende Klemmhalter auf Seite // Suitable toolholders on page
171, 172, 173, 178, 180, 181

SP **HM** **R** Legende **238**
Legend

Scan QR-Code Oder besuchen Sie // Or Visit
www.simtek.info/cp/823



Abbildung zeigt / Drawing shows: D11.0815.02 MR

HC	Steigung TP Pitch TP	Artikelnummer Part number	Webcode www.simtek.com/webcode	Empfohlene Schneidstoffe Tagesaktuelle Verfügbarkeit und Preise finden Sie auf www.simtek.com/webcode Recommended cutting grades You can find current availability and prices on www.simtek.com/webcode							a	b	Ød	HA	HB	ØDmin (Min. Bohrung) ØDmin (min. bore)	f	S	Connectcode www.simtek.com/code
				P	K	M	N	S	H	O									
▼ ØDmin (Min. Bohrung) // ØDmin (min. bore) = 9,0 mm																			
0,271	0,5	D09.0205.02.09 MR/L	R AWGT L AWH6	X800	X400	GX79	X500	X400	8,6	3,65	6,2	0,325	0,054	9,0	5,5	3,25	D09	upd	
0,541	1,0	D09.0510.02.09 MR/L	R AWGS L AWH5	X800	X400	GX79	X500	X400	8,6	3,65	6,2	0,65	0,108	9,0	5,5	3,0	D09	upd	
0,812	1,5	D09.0815.02.09 MR/L	R AWGQ L AWH4	X800	X400	GX79	X500	X400	8,6	3,6	6,2	0,974	0,162	9,0	5,5	2,8	D09	upd	
0,947	1,75	D09.0917.02.09 MR/L	R AWGP L AWH3	X800	X400	GX79	X500	X400	8,6	3,6	6,2	1,137	0,189	9,0	5,5	2,7	D09	upd	
1,083	2,0	D09.1020.02.09 MR/L	R AWGN L AWH2	X800	X400	GX79	X500	X400	8,6	3,58	6,2	1,299	0,217	9,0	5,5	2,6	D09	upd	
1,353	2,5	D09.1325.02.09 MR/L	R AWGM L AWH1	X800	X400	GX79	X500	X400	8,6	3,56	6,2	1,624	0,271	9,0	5,5	2,5	D09	upd	
1,624	3,0	D09.1630.02.09 MR/L	R AWGK L AWH0	X800	X400	GX79	X500	X400	8,6	3,54	6,2	1,949	0,325	9,0	5,5	2,2	D09	upd	
▼ ØDmin (Min. Bohrung) // ØDmin (min. bore) = 10,0 mm																			
0,271	0,5	D10.0205.02.10 MR/L	R ANVA L ADJC	X800	X400	GX79	X500	X400	9,3	3,8	7,0	0,325	0,054	10,0	5,8	3,4	D10	upd	
0,541	1,0	D10.0510.02.10 MR/L	R ANP1 L ADAV	X800	X400	GX79	X500	X400	9,3	4,0	7,0	0,65	0,108	10,0	5,8	3,2	D10	upd	
0,812	1,5	D10.0815.02.10 MR/L	R AM2E L AA2U	X800	X400	GX79	X500	X400	9,3	3,9	7,0	0,974	0,162	10,0	5,8	3,0	D10	upd	
0,947	1,75	D10.0917.02.10 MR/L	R AD6Z L ABYB	X800	X400	GX79	X500	X400	9,3	3,9	7,0	1,137	0,189	10,0	5,8	2,9	D10	upd	
1,083	2,0	D10.1020.02.10 MR/L	R AADQ L AKFM	X800	X400	GX79	X500	X400	9,3	3,9	7,0	1,299	0,217	10,0	5,8	2,75	D10	upd	
1,353	2,5	D10.1325.02.10 MR/L	R AAG5 L AMY3	X800	X400	GX79	X500	X400	9,3	3,8	7,0	1,624	0,271	10,0	5,8	2,5	D10	upd	
1,624	3,0	D10.1630.02.10 MR/L	R AJXD L AKWA	X800	X400	GX79	X500	X400	9,3	3,8	7,0	1,949	0,325	10,0	5,8	2,45	D10	upd	
▼ ØDmin (Min. Bohrung) // ØDmin (min. bore) = 11,0 mm																			
0,541	1,0	D11.0510.02 MR/L	R AJ3B L AF7P	X800	X400	GX79	X500	X400	10,7	4,3	8,0	0,65	0,108	11,0	6,7	3,6	D11	upd	
0,812	1,5	D11.0815.02 MR/L	R AESU L APF7	X800	X400	GX79	X500	X400	10,7	4,3	8,0	0,974	0,162	11,0	6,7	3,3	D11	upd	
1,083	2,0	D11.1020.02 MR/L	R AF4G L ACVY	X800	X400	GX79	X500	X400	10,7	4,3	8,0	1,299	0,217	11,0	6,7	2,9	D11	upd	
1,353	2,5	D11.1325.02 MR/L	R AN9M L ACTN	X800	X400	GX79	X500	X400	10,7	4,3	8,0	1,624	0,271	11,0	6,7	2,95	D11	upd	
1,624	3,0	D11.1630.02 MR/L	R AKVC L AJZG	X800	X400	GX79	X500	X400	10,7	4,3	8,0	1,949	0,325	11,0	6,7	2,9	D11	upd	

Verwandte Werkzeuge finden Sie auch auf der folgenden Seite!
Related Items can be found on the following page as well!

Fortgesetzte Tabelle
Continued Table

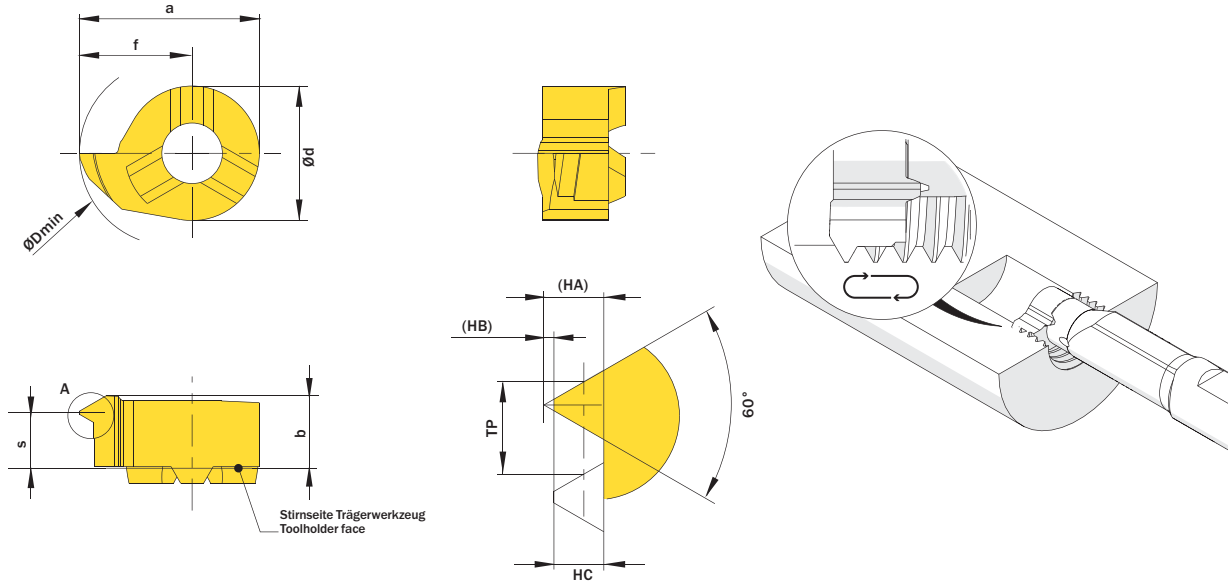
Bestellbeispiel // Order example: **D11.1020.02 MR X800** (R = Rechte Ausführung // Right hand version, X800 = Schneidstoff // Grade)

simturn AX
simturn DX
simturn PX
simturn H2
simturn K2
simturn GX
simturn E3
simturn E12
simturn FX
simturn Decolletage
simturn OA
Index