

# Klemmhalter, Innenbearbeitung

Schwingungsgedämpfter Hartmetall-Rundschaft mit innerer Kühlmittelzufuhr.

## Toolholder, For Internal Applications

Anti-vibration solid carbide round shank toolholder with through coolant.

Anzugsmoment (Schraube) // Tightening torque (screw)

**1,5 Nm**

Bitte Hinweise im Anhang beachten // Please read add. notes

**MASTER (Seite/Page 212)**



Legende  
Legend **213**



Scan  
QR-Code

Oder besuchen Sie // Or Visit  
[www.simtek.info/cp/989](http://www.simtek.info/cp/989)

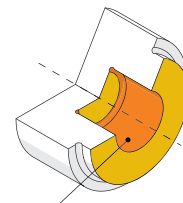
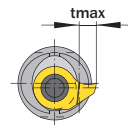
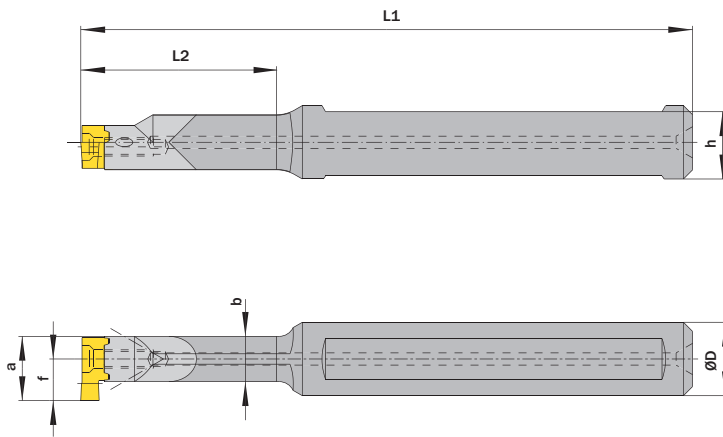

Maße „a“, „f“ und „tmax“ sind abhängig vom verwendeten Schneideinsatz.  
Dimensions „a“, „f“ and tmax depend on used carbide inserts.

- Hauptsächlich geeignet für diese Flächen  
Mainly designed for these surfaces
- Je nach Schneidplatte ebenfalls möglich  
Also possible depending on insert type

<b>ØD</b> <sup>h6</sup>	<b>L2</b>	Artikelnummer Part number	Webcode <a href="http://www.simtek.com/webcode">www.simtek.com/webcode</a>	<b>b</b>	<b>h</b>	<b>L1</b>	Schraube Screw	Schraubenschlüssel Screw driver	Connectcode <a href="http://www.simtek.com/code">www.simtek.com/code</a>
mm	mm			mm	mm	mm			

◀ Fortgesetzte Tabelle  
Continued Table

Verwandte Werkzeuge finden Sie auch auf der vorhergehenden Seite!  
Related Items can be found on the previous page as well!

▼ ØD = 12,0 mm									
12,0	22,0	<b>D09.0012.22 HM</b>	AWFD	6,6	11,0	90,0	D M2,6x8 T8F	T8F	D09
12,0	30,0	<b>D09.0012.30 HM</b>	AWFC	6,6	11,0	98,0	D M2,6x8 T8F	T8F	D09
12,0	42,0	<b>D09.0012.42 HM</b>	AWFB	6,6	11,0	110,0	D M2,6x8 T8F	T8F	D09
12,0	56,0	<b>D09.0012.56 HM</b>	AWFA	6,6	11,0	122,0	D M2,6x8 T8F	T8F	D09
▼ ØD = 12,7 mm									
12,7	22,0	<b>D09.0.500.22 HM</b>	A23Z	6,6	11,7	90,0	D M2,6x8 T8F	T8F	D09 <small>new inch</small>
12,7	30,0	<b>D09.0.500.30 HM</b>	A230	6,6	11,7	98,0	D M2,6x8 T8F	T8F	D09 <small>new inch</small>
12,7	42,0	<b>D09.0.500.42 HM</b>	A231	6,6	11,7	110,0	D M2,6x8 T8F	T8F	D09 <small>new inch</small>
12,7	56,0	<b>D09.0500.56 HM</b>	A5T3	6,6	11,7	122,0	D M2,6x8 T8F	T8F	D09 <small>new inch</small>

Verwandte Werkzeuge finden Sie auch auf der folgenden Seite!  
Related Items can be found on the following page as well!

▶ Fortgesetzte Tabelle  
Continued Table

Bestellbeispiel // Order example: **D09.0012.42 HM**