

Gewindedrehen, Trapezgewinde, Teilprofil

Teilprofil für Trapez-Gewinde.

Threading, Trapezoidal Partial Profile

Partial profile for internal trapezoidal-thread.

Schnittwerte (Start) // Cutting parameters (start)

Anzahl Durchgänge // Number of passes **12 - 18**

Empf. Zustellungsart // Recom. infeed method
Modifizierte einseitige Flankenzustellung // Modified one-sided flank infeed (Seite/Page 447)

Vc
Seite/Page 442

Passende Klemmhalter auf Seite // Suitable toolholders on page
171, 172, 173, 174, 176, 178, 180, 181



Legende
Legend **238**



Scan
QR-Code

Oder besuchen Sie // Or Visit
www.simtek.info/cp/825

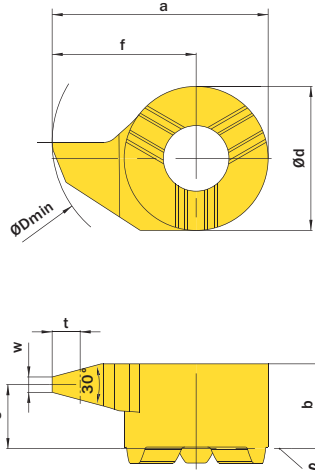

Stirnseite-Klemmhalter
Toolholder face

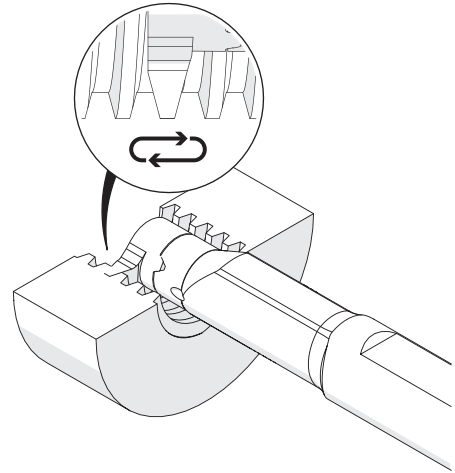

Abbildung zeigt / Drawing shows: D14.1730.01 MR

Ab Gewindegröße As of thread size	t mm	Steigung (von) Pitch (as of)	Artikelnummer Part number	Webcode www.simtek.com/webcode	Empfohlene Schneidstoffe Tagesaktuelle Verfügbarkeit und Preise finden Sie auf www.simtek.com/webcode Recommended cutting grades You can find current availability and prices on www.simtek.com/webcode	a	b	Ød	ØDmin (Min. Bohrung) ØDmin (min. bore)	f	S	w	Connectcode www.simtek.com/ccode
▼ Ab Gewindegröße // As of thread size = 12,0													
12,0	0,9	1,5	D09.TR15.01.09 MR/L	R AWF1 L AWHE	X800 X400 X600 GX79 X500 X400	8,6	3,55	6,2	9,0	5,5	3,0	0,47	D09
12,0	1,25	2,0	D09.TR20.01.09 MR/L	R AWF0 L AWHD	X800 X400 X600 GX79 X500 X400	8,6	3,55	6,2	9,0	5,5	2,85	0,6	D09
12,0	0,9	1,5	D10.TR15.01.10 MR/L	R ASBH L ASBG	X800 X400 X600 GX79 X500 X400	9,3	3,95	7,0	10,0	5,8	3,32	0,47	D10
▼ Ab Gewindegröße // As of thread size = 14,0													
14,0	1,75	3,0	D09.TR30.01.09 MR/L	R AWFZ L AWHC	X800 X400 X600 GX79 X500 X400	8,6	3,55	6,2	9,0	5,5	2,25	0,96	D09
14,0	1,25	2,0	D10.TR20.01.10 MR/L	R ASBK L ASBJ	X800 X400 X600 GX79 X500 X400	9,3	3,7	7,0	10,0	5,8	2,91	0,6	D10
14,0	1,75	3,0	D10.TR30.01.10 MR/L	R ASBN L ASBM	X800 X400 X600 GX79 X500 X400	9,3	3,7	7,0	10,0	5,8	2,57	0,96	D10
14,0	0,9	1,5	D11.1015.01 MR/L	R AA9G L AAQ0	X800 X400 X600 GX79 X500 X400	10,7	4,3	8,0	11,0	6,7	3,7	0,47	D11
14,0	1,25	2,0	D11.1220.01 MR/L	R AF6J L AH27	X800 X400 X600 GX79 X500 X400	10,7	4,3	8,0	11,0	6,7	3,5	0,6	D11
▼ Ab Gewindegröße // As of thread size = 16,0													
16,0	2,25	4,0	D09.TR40.01.10 MR/L	R AWFY L AWHB	X800 X400 X600 GX79 X500 X400	9,6	3,55	6,2	10,0	6,5	2,25	1,33	D09
16,0	2,25	4,0	D10.TR40.01.11 MR/L	R ASBQ L ASBP	X800 X400 X600 GX79 X500 X400	10,3	3,7	7,0	11,0	6,8	2,14	1,33	D10
16,0	1,75	3,0	D11.1730.01 MR/L	R AP1Y L AMT5	X800 X400 X600 GX79 X500 X400	10,7	4,3	8,0	11,0	6,7	3,2	0,96	D11
16,0	2,25	4,0	D11.2240.01 MR/L	R ANXG L AFT8	X800 X400 X600 GX79 X500 X400	10,7	4,0	8,0	11,0	6,7	2,6	1,33	D11
▼ Ab Gewindegröße // As of thread size = 18,0													
18,0	1,25	2,0	D14.1220.01 MR/L	R AD11 L AFN9	X800 X400 X600 GX79 X500 X400	13,5	5,3	9,0	14,0	9,0	4,3	0,6	D14
18,0	1,75	3,0	D14.1730.01 MR/L	R AMAN L ANQF	X800 X400 X600 GX79 X500 X400	13,5	5,3	9,0	14,0	9,0	4,0	0,96	D14
▼ Ab Gewindegröße // As of thread size = 20,0													
20,0	2,25	4,0	D14.2240.01 MR/L	R AGYM L AKD9	X800 X400 X600 GX79 X500 X400	13,5	5,3	9,0	14,0	9,0	4,0	1,33	D14
20,0	1,25	2,0	D16.1220.01 MR/L	R AGNW L AAX2	X800 X400 X600 GX79 X500 X400	15,2	5,5	11,0	16,0	9,7	4,5	0,6	D16
20,0	1,75	3,0	D16.1730.01 MR/L	R AG99 L AM5S	X800 X400 X600 GX79 X500 X400	15,2	5,5	11,0	16,0	9,7	4,3	0,96	D16
▼ Ab Gewindegröße // As of thread size = 22,0													
22,0	2,75	5,0	D14.2750.01 MR/L	R AJ51 L AA01	X800 X400 X600 GX79 X500 X400	13,5	5,3	9,0	14,0	9,0	3,55	1,69	D14
22,0	2,25	4,0	D16.2240.01 MR/L	R ANBP L ACCX	X800 X400 X600 GX79 X500 X400	15,2	5,5	11,0	16,0	9,7	4,0	1,33	D16
22,0	2,75	5,0	D16.2750.01 MR/L	R APG1 L ANCP	X800 X400 X600 GX79 X500 X400	15,7	5,5	11,0	16,0	10,2	3,6	1,69	D16
▼ Ab Gewindegröße // As of thread size = 32,0													
32,0	3,5	6,0	D16.3560.01 MR/L	R AEJX L APZ5	X800 X400 X600 GX79 X500 X400	15,7	5,5	11,0	16,0	10,2	3,3	1,92	D16

Bestellbeispiel // Order example: D14.2240.01 MR X800 (R = Rechte Ausführung // Right hand version, X800 = Schneidstoff // Grade)