

Axialeinstiche in Zapfen, Vollradius

Geeignet ab Bohrungsdurchmesser 12,0 mm.

Face Grooving on Pivots, Full Radius

For use in bores as of minimum bore diameter 12,0 mm.

Schnittwerte (Start) // Cutting parameters (start)

f	Vc
0,02 mm/U	Seite/Page 429

Passende Klemmhalter auf Seite // Suitable toolholders on page
165, 166, 167

SP
HM

R

Legende
Legend

213

Scan
QR-Code

Oder besuchen Sie // Or Visit
www.simtek.info/cp/964

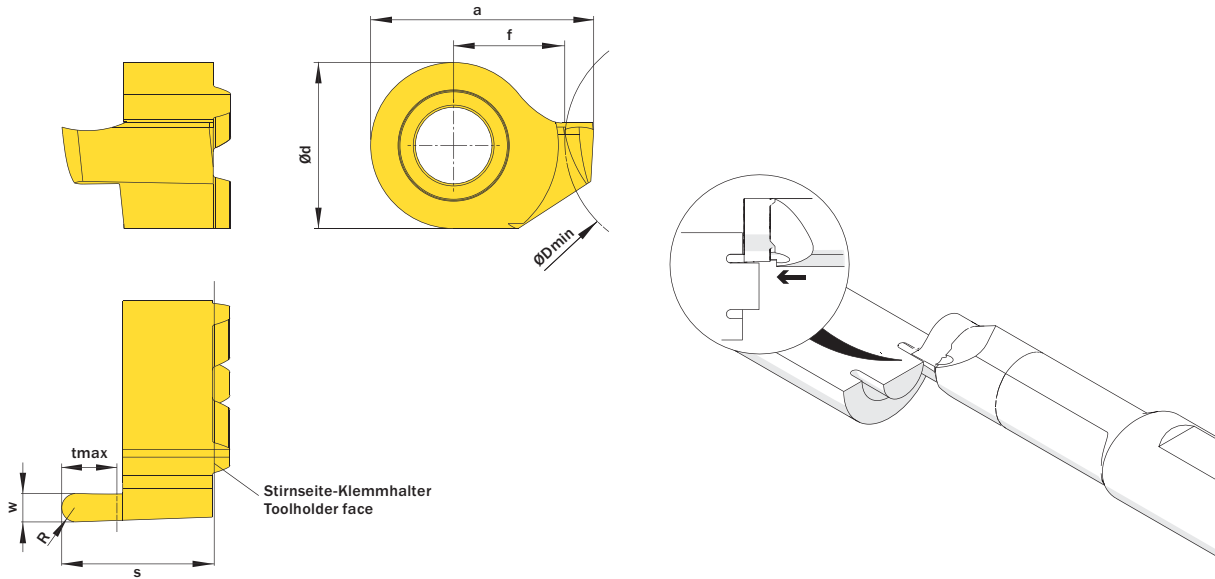

Abbildung zeigt / Drawing shows: D14.1216.08 AR

ØDmin (Min. Bohrung) ØDmin (min. bore)	w ^{+0,03}	R	Artikelnummer Part number	Webcode www.simtek.com/webcode	Unsere erste Wahl Our first choice	a	Ød	f	S	tmax	Connectcode www.simtek.com/ccode
mm	mm	mm			P K M N S	mm	mm	mm	mm	mm	
▼ tmax = 1,5 mm											
12,0	1,0	0,5	D14.1210.05 AR/L	R AU6C L AU6B	X800 X400	11,5	9,0	6,0	8,3	1,5	R D14.A.R L D14.A.L
▼ tmax = 2,5 mm											
12,0	1,5	0,75	D14.1215.07 AR/L	R A08G L A08F	X800 X400	12,0	9,0	6,0	8,3	2,5	R D14.A.R L D14.A.L
12,0	1,6	0,8	D14.1216.08 AR/L	R AU6E L AU6D	X800 X400	12,1	9,0	6,0	8,3	2,5	R D14.A.R L D14.A.L
▼ tmax = 3,0 mm											
12,0	2,0	1,0	D14.1220.10 AR/L	R AU6G L AU6F	X800 X400	12,5	9,0	6,0	8,3	3,0	R D14.A.R L D14.A.L
12,0	2,5	1,25	D14.1225.12 AR/L	R AU6J L AU6H	X800 X400	13,0	9,0	6,0	8,3	3,0	R D14.A.R L D14.A.L
12,0	3,0	1,5	D14.1230.15 AR/L	R AU6M L AU6K	X800 X400	13,5	9,0	6,0	8,3	3,0	R D14.A.R L D14.A.L
▼ tmax = 5,0 mm											
12,0	2,0	1,0	D14.1220.50 AV R/L	R AWEZ L AWEY	X800 X400	12,5	9,0	6,0	10,3	5,0	R D14.A.R L D14.A.L
12,0	2,5	1,25	D14.1225.50 AV R/L	R AWE1 L AWE0	X800 X400	13,0	9,0	6,0	10,3	5,0	R D14.A.R L D14.A.L
12,0	3,0	1,5	D14.1230.50 AV R/L	R AWE3 L AWE2	X800 X400	13,5	9,0	6,0	10,3	5,0	R D14.A.R L D14.A.L

Bestellbeispiel // Order example: **D14.1220.50 AV R X800** (R = Rechte Ausführung // Right hand version, X800 = Schneidstoff // Grade)