

Klemmhalter / Adapter, Innenbearbeitung

Adapter für simmill OS D07- oder simmill OS D10-Schneidplatten auf precium Feinausdrehwerkzeuge. Schwingungsgedämpfter Hartmetall-Rundschaft mit Kühlmittelzufuhr.

Toolholder / Adapter, For Internal Applications

Adapter for simmill OS D07 or simmill OS D10 inserts on precium fine boring units. Anti-vibration solid carbide round shank toolholder with through coolant.

Anzugsmoment (Schraube) // Tightening torque (screw)

"D M2x7,5 T7F": 1,2 Nm
 "D M3x9 T9F": 2,1 Nm

Bitte Hinweise im Anhang beachten // Please read add. notes

ALL (Seite/Page 645)



Legende Legend 650



Scan QR-Code

Oder besuchen Sie // Or Visit www.simtek.info/cp/1059

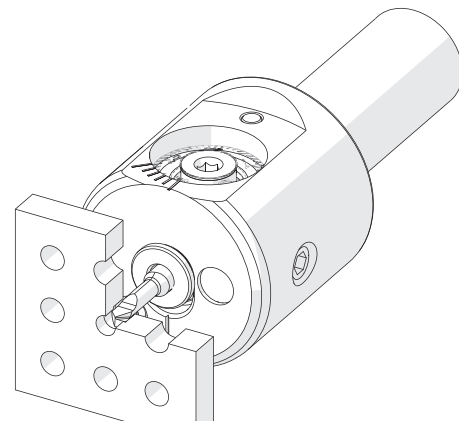
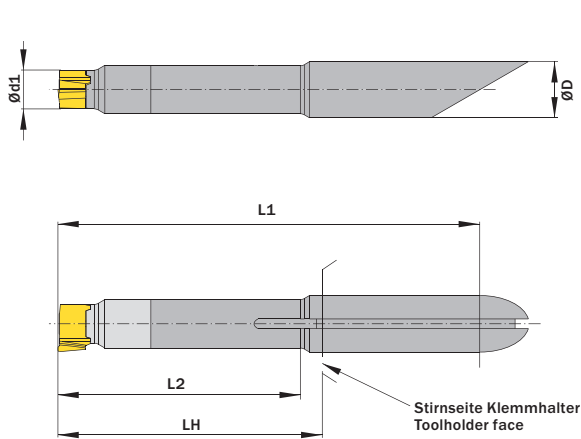

Illustration zeigt beispielhafte Anwendungsmöglichkeit mit ähnlichem Werkzeug.
 Image shows exemplary application possibility with similar tool.

Abbildung zeigt / Drawing shows: D07.A07.30 HM

ØD ^{h6} mm	L2 mm	Artikelnummer Part number	Webcode www.simtek.com/webcode	Ød1 mm	ØDmin (Min. Bohrung) ØDmin (min. bore) mm	L1 mm	LH mm	Schraube Screw	Schraubenschlüssel Screw driver	Connectcode www.simtek.com/code
▼ L2 = 30,0 mm										
7,0	30,0	D07.A07.30 HM	AW1M	4,8	6,9	52,2	33,0	D M2x7,5 T7F	T7F	MOS.D07
▼ L2 = 35,0 mm										
7,0	35,0	D10.A07.35 HM	AW1S	7,0	9,9	57,2	38,0	D M3x9 T9F	T9F	MOS.D10
▼ L2 = 50,0 mm										
7,0	50,0	D10.A07.50 HM	AX0T	7,0	9,9	72,2	53,0	D M3x9 T9F	T9F	MOS.D10

Bestellbeispiel // Order example: **D10.A07.35 HM**

simmill AX

simmill PMX

simmill PX

simmill SX

simmill UX

simmill VX

simmill H2

simmill K2

simmill MX

simmill OS

Index