

Feinausdrehen

Ausspindeln von Bohrungen auf precium Feinausdrehwerkzeugen.

Fine Boring

Fine boring on precium fine boring units.

Bitte Hinweise im Anhang beachten // Please read add. notes
ALL (Seite/Page 645)



SP
 HM R

Legende
 Legend **650**

Scan
 QR-Code

Oder besuchen Sie // Or Visit
www.simtek.info/cp/1009

Mehr Informationen unter www.precium.de
 More information on www.precium.de

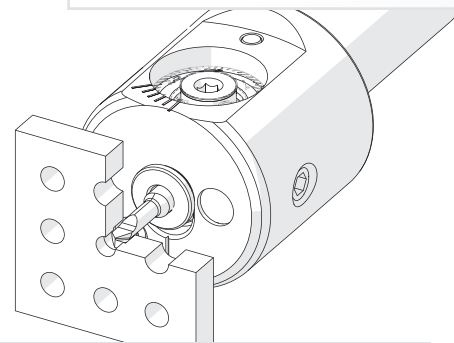
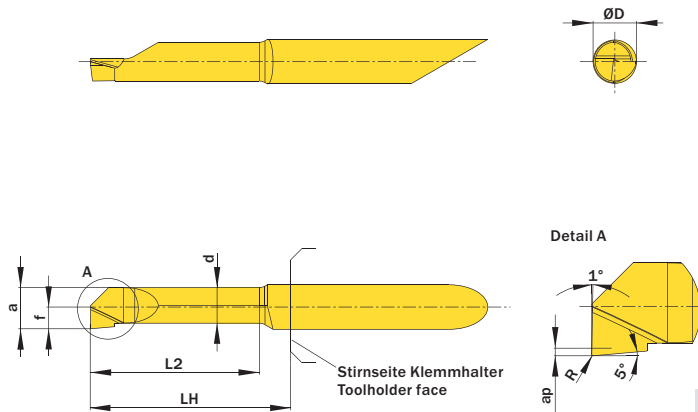

Illustration zeigt beispielhafte Anwendungsmöglichkeit mit ähnlichem Werkzeug.
 Image shows exemplary application possibility with similar tool.

Abbildung zeigt / Drawing shows: A04.0195.15.39.05 Y R

ØD	L2	ØDmin (Min. Bohrung) ØDmin (min. bore)	R	AXC	Artikelnummer Part number	Webcode www.simtek.com/webcode	Unsere erste Wahl Our first choice	a	d	f	LH	ap	Connectcode www.simtek.com/ccode
mm	mm	mm	mm				P M K N S	mm	mm	mm	mm	mm	
▼ ØDmin (Min. Bohrung) // ØDmin (min. bore) = 0,3 mm													
4,0	1,2	0,3	-	0	A04.0010.01.03.00 YR	AW08	X800 GT42	0,25	0,19	0,15	13,0	0,03	MOS.A04.R
▼ ØDmin (Min. Bohrung) // ØDmin (min. bore) = 0,6 mm													
4,0	2,5	0,6	-	0	A04.0025.02.06.00 YR	AW09	X800 GT42	0,55	0,46	0,3	13,0	0,05	MOS.A04.R
▼ ØDmin (Min. Bohrung) // ØDmin (min. bore) = 1,0 mm													
4,0	4,0	1,0	0,05	0	A04.0045.04.10.05 YR	AW1A	X800 GT42	0,95	0,8	0,5	13,0	0,1	MOS.A04.R
4,0	6,0	1,0	0,05	0	A04.0045.06.10.05 YR	AX0U	X800 GT42	0,95	0,8	0,5	13,0	0,1	MOS.A04.R
▼ ØDmin (Min. Bohrung) // ØDmin (min. bore) = 2,2 mm													
4,0	6,0	2,2	0,05	1	A04.0095.06.22.05 YR	AW1B	X800 GT42	2,0	1,55	1,1	13,0	0,2	MOS.A04.R
4,0	9,1	2,2	0,05	1	A04.0095.09.22.05 YR	AX0V	X800 GT42	2,0	1,55	1,1	13,0	0,2	MOS.A04.R
▼ ØDmin (Min. Bohrung) // ØDmin (min. bore) = 3,2 mm													
4,0	10,2	3,2	0,05	1	A04.0145.10.32.05 YR	AW1C	X800 GT42	3,0	2,55	1,6	13,0	0,2	MOS.A04.R
4,0	15,2	3,2	0,05	1	A04.0145.15.32.05 YR	AX0W	X800 GT42	3,0	2,55	1,6	18,0	0,2	MOS.A04.R
4,0	20,3	3,2	0,05	1	A04.0145.20.32.05 YR	AX0X	X800 GT42	3,0	2,55	1,6	23,0	0,2	MOS.A04.R
▼ ØDmin (Min. Bohrung) // ØDmin (min. bore) = 3,9 mm													
4,0	15,2	3,9	0,05	1	A04.0195.15.39.05 YR	AW1D	X800 GT42	3,7	3,2	1,95	18,0	0,3	MOS.A04.R
4,0	20,3	3,9	0,05	1	A04.0195.20.39.05 YR	AX0Y	X800 GT42	3,7	3,2	1,95	23,0	0,3	MOS.A04.R
4,0	25,4	3,9	0,05	1	A04.0195.25.39.05 YR	AX0Z	X800 GT42	3,7	3,2	1,95	28,0	0,3	MOS.A04.R
▼ ØDmin (Min. Bohrung) // ØDmin (min. bore) = 5,2 mm													
7,0	20,3	5,2	0,05	1	A07.0245.20.52.05 YR	AW1E	X800 GT42	5,0	4,25	2,6	23,0	0,5	MOS.A07.R
7,0	25,4	5,2	0,05	1	A07.0245.25.52.05 YR	AX00	X800 GT42	5,0	4,25	2,6	28,0	0,5	MOS.A07.R
7,0	30,5	5,2	0,05	1	A07.0245.30.52.05 YR	AX01	X800 GT42	5,0	4,25	2,6	33,0	0,5	MOS.A07.R
▼ ØDmin (Min. Bohrung) // ØDmin (min. bore) = 6,2 mm													
7,0	20,3	6,2	0,05	1	A07.0295.20.62.05 YR	AW1F	X800 GT42	6,0	5,25	3,1	23,0	0,5	MOS.A07.R
7,0	25,4	6,2	0,05	1	A07.0295.25.62.05 YR	AX02	X800 GT42	6,0	5,25	3,1	28,0	0,5	MOS.A07.R
7,0	30,5	6,2	0,05	1	A07.0295.30.62.05 YR	AX03	X800 GT42	6,0	5,25	3,1	33,0	0,5	MOS.A07.R
▼ ØDmin (Min. Bohrung) // ØDmin (min. bore) = 6,9 mm													
7,0	25,4	6,9	0,2	1	A07.0345.25.69.20 YR	AW1G	X800 GT42	6,7	6,0	3,45	28,0	0,5	MOS.A07.R
7,0	30,5	6,9	0,2	1	A07.0345.30.69.20 YR	AX04	X800 GT42	6,7	6,0	3,45	33,0	0,5	MOS.A07.R
7,0	40,6	6,9	0,2	1	A07.0345.40.69.20 YR	AX05	X800 GT42	6,7	6,0	3,45	43,0	0,5	MOS.A07.R

Bestellbeispiel // Order example: A04.0195.15.39.05 YR X800 (R = Rechte Ausführung // Right hand version, X800 = Schneidstoff // Grade)