

Klemmhalter, Innenbearbeitung, Rundschaft

Rundschaft mit innerer Kühlmittelzufuhr für die Größe A10.
Vier Kühlmittelzufuhrarten je nach Bedarf einstellbar.

Toolholder, Internal Applications, Round Shank

Round shank with through coolant for size A10.
Four different types of through coolant supply can be realized as required.

Anzugsmoment (Schraube) // Tightening torque (screw)

7,0 Nm

Bitte Hinweise im Anhang beachten // Please read add. notes

MASTER (Seite/Page 137)



Legende
Legend

139



Scan
QR-Code

Oder besuchen Sie // Or Visit
www.simtek.info/cp/1205

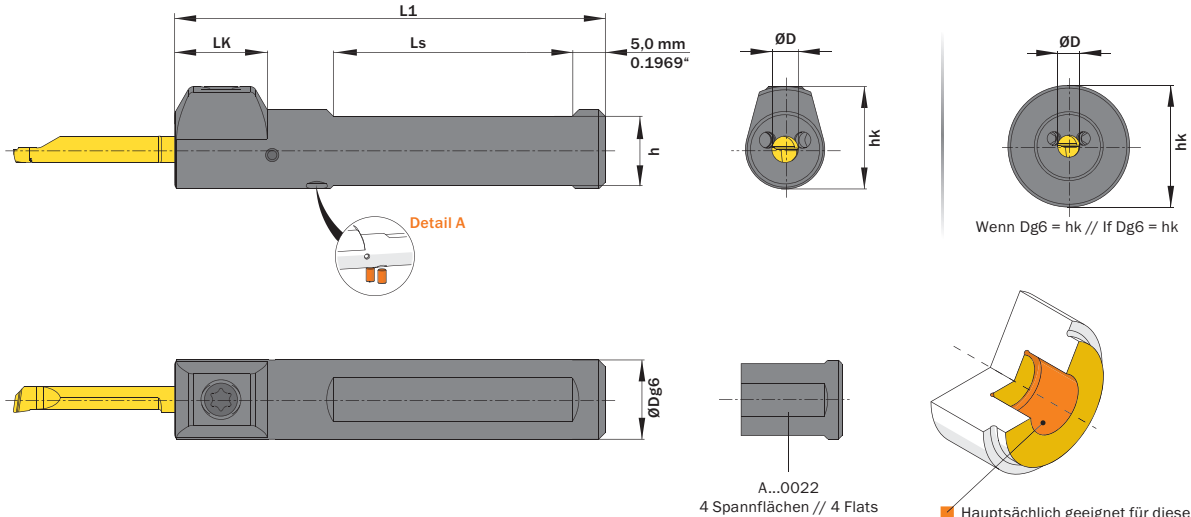

- Hauptsächlich geeignet für diese Flächen
Mainly designed for these surfaces
- Je nach Schneidplatte ebenfalls möglich
Also possible depending on insert type

ØD	ØDg6	Artikelnummer Part number	Webcode www.simtek.com/webcode	h	hk	L1	LK	Ls	Anzahl Spannflächen Number of flats	Schraube Screw	Schraubenschlüssel Screw driver	Connectcode www.simtek.com/code
mm	mm			mm	mm	mm	mm	mm				

Fortgesetzte Tabelle
Continued Table

Verwandte Werkzeuge finden Sie auch auf der vorhergehenden Seite!
Related items can be found on the previous page as well!

10,0	19,05	A10.0.750 T	AUV8	17,05	24,0	110,0	14,0	81,0	2	A M6x7,5T15F	T15F	A10.L A10.R A10T	Inch
10,0	20,0	A10.0020 T	AUWB	18,0	25,0	90,0	14,0	61,0	2	A M6x7,5T15F	T15F	A10.L A10.R A10T	
10,0	22,0	A10.0022 T	AØ74	20,94	25,0	110,0	14,0	90,0	4	A M6x7,5T15F	T15F	A10.L A10.R A10T	upd
10,0	25,0	A10.0025 T	AUWE	23,0	25,0	110,0	-	90,0	2	A M6x7,5T15F	T15F	A10.L A10.R A10T	
10,0	25,4	A10.1.000 T	AUWH	23,4	25,4	110,0	-	90,0	2	A M6x7,5T15F	T15F	A10.L A10.R A10T	new Inch

Bestellbeispiel // Order example: **A10.0020 T**

Detail A | 1 Halter – 4 Kühlmittelzufuhrarten // 1 Toolholder – 4 types of coolant supply

