

Klemmhalter, Innenbearbeitung, Rundschaft

Rundschaft mit innerer Kühlmittelzufuhr für die Größe A07.
Vier Kühlmittelzufuhrarten je nach Bedarf einstellbar.

Toolholder, Internal Applications, Round Shank

Round shank with through coolant for size A07.
Four different types of through coolant supply can be realized as required.

Anzugsmoment (Schraube) // Tightening torque (screw)

7,0 Nm

Bitte Hinweise im Anhang beachten // Please read add. notes

MASTER (Seite/Page 137)



Legende
Legend

139



Scan
QR-Code

Oder besuchen Sie // Or Visit
www.simtek.info/cp/1203

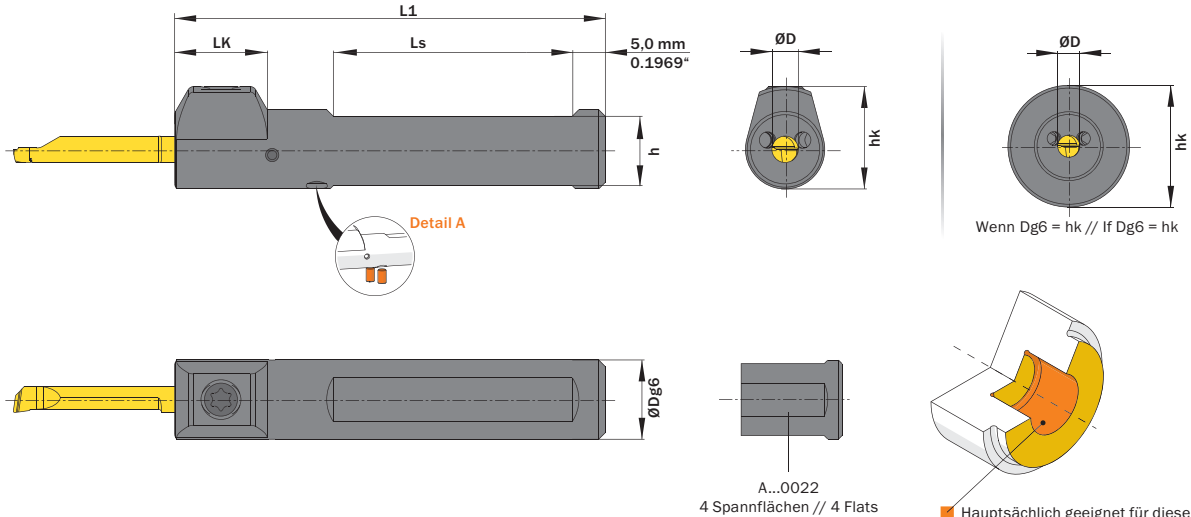

ØD	ØDg6	Artikelnummer Part number	Webcode www.simtek.com/webcode	h	hk	L1	LK	Ls	Anzahl Spannflächen Number of flats	Schraube Screw	Schraubenschlüssel Screw driver	Connectcode www.simtek.com/code
mm	mm			mm	mm	mm	mm	mm				

Fortgesetzte Tabelle
Continued Table

Verwandte Werkzeuge finden Sie auch auf der vorhergehenden Seite!
Related items can be found on the previous page as well!

7,0	15,875	A07.0.625 T	AUU1	13,88	18,94	75,0	14,0	46,0	2	A M6x7,5 T15F	T15F	A07L A07R A07T	Inch
7,0	16,0	A07.0016 T	AUU4	14,0	19,0	75,0	14,0	46,0	2	A M6x7,5 T15F	T15F	A07L A07R A07T	
7,0	19,05	A07.0.750 T	AUUY	17,05	21,0	110,0	14,0	81,0	2	A M6x7,5 T15F	T15F	A07L A07R A07T	Inch
7,0	20,0	A07.0020 T	AUVD	18,0	22,0	90,0	14,0	61,0	2	A M6x7,5 T15F	T15F	A07L A07R A07T	
7,0	22,0	A07.0022 T	AUU7	20,0	22,0	110,0	-	90,0	4	A M6x7,5 T15F	T15F	A07L A07R A07T	
7,0	25,0	A07.0025 T	AUVA	23,0	25,0	110,0	-	90,0	2	A M6x7,5 T15F	T15F	A07L A07R A07T	
7,0	25,4	A07.1.000 T	AUVK	23,4	25,4	110,0	-	90,0	2	A M6x7,5 T15F	T15F	A07L A07R A07T	Inch

Verwandte Werkzeuge finden Sie auch auf der folgenden Seite!
Related items can be found on the following page as well!

Fortgesetzte Tabelle
Continued Table

Bestellbeispiel // Order example: **A07.0016 T**

Detail A | 1 Halter - 4 Kühlmittelzufuhrarten // 1 Toolholder - 4 types of coolant supply

