

Klemmhalter, Innenbearbeitung, Rundschaft

Rundschaft mit innerer Kühlmittelzufuhr für die Größe A06.
Vier Kühlmittelzufuhrarten je nach Bedarf einstellbar.

Toolholder, Internal Applications, Round Shank

Round shank with through coolant for size A06.
Four different types of through coolant supply can be realized as required.

Anzugsmoment (Schraube) // Tightening torque (screw)

7,0 Nm

Bitte Hinweise im Anhang beachten // Please read add. notes

MASTER (Seite/Page 137)



Legende
Legend

139



Scan
QR-Code

Oder besuchen Sie // Or Visit
www.simtek.info/cp/1202

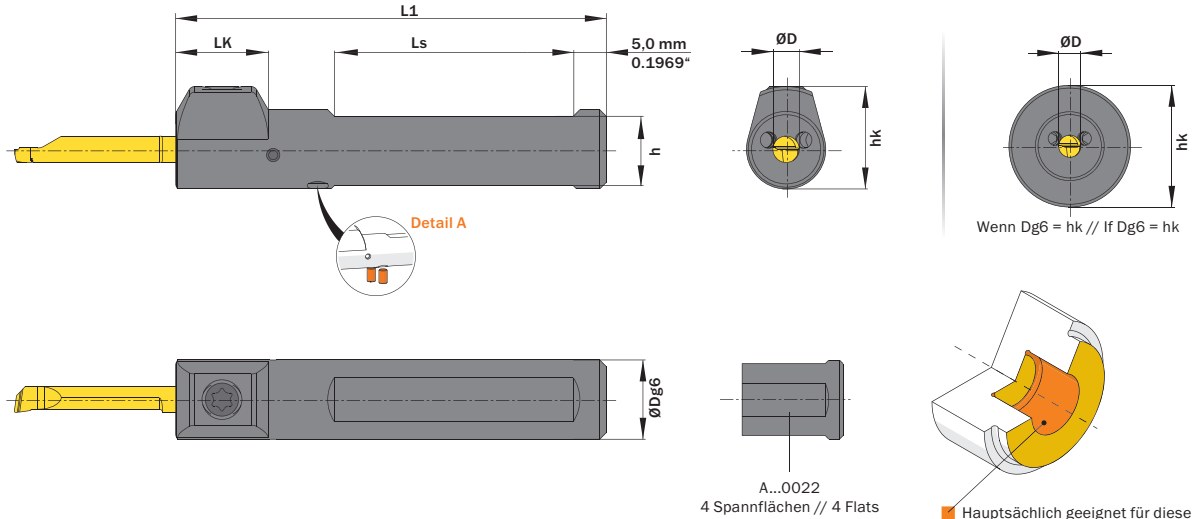

ØD	ØDg6	Artikelnummer Part number	Webcode www.simtek.com/webcode	h	hk	L1	LK	Ls	Anzahl Spannflächen Number of flats	Schraube Screw	Schraubenschlüssel Screw driver	Connectcode www.simtek.com/code
mm	mm			mm	mm	mm	mm	mm				

Fortgesetzte Tabelle
Continued Table

Verwandte Werkzeuge finden Sie auch auf der vorhergehenden Seite!
Related items can be found on the previous page as well!

6,0	12,0	A06.0012 T	AUT9	10,5	16,5	70,0	14,0	41,0	2	A M6x7,5 T15F	T15F	A06.L A06.R A06T
6,0	15,875	A06.0.625 T	AUT0	13,88	18,44	75,0	14,0	46,0	2	A M6x7,5 T15F	T15F	A06.L A06.R A06T
6,0	16,0	A06.0016 T	AUUC	14,0	18,5	75,0	14,0	46,0	2	A M6x7,5 T15F	T15F	A06.L A06.R A06T
6,0	19,05	A06.0.750 T	AUT6	17,05	19,05	110,0	14,0	81,0	2	A M6x7,5 T15F	T15F	A06.L A06.R A06T
6,0	20,0	A06.0020 T	AUUN	18,0	20,0	90,0	14,0	61,0	2	A M6x7,5 T15F	T15F	A06.L A06.R A06T
6,0	22,0	A06.0022 T	AUUF	20,0	22,0	110,0	-	90,0	4	A M6x7,5 T15F	T15F	A06.L A06.R A06T
6,0	25,0	A06.0025 T	AUUJ	23,0	25,0	110,0	-	90,0	2	A M6x7,5 T15F	T15F	A06.L A06.R A06T
6,0	25,4	A06.1.000 T	AUUU	23,4	25,4	110,0	-	90,0	2	A M6x7,5 T15F	T15F	A06.L A06.R A06T

Verwandte Werkzeuge finden Sie auch auf der folgenden Seite!
Related items can be found on the following page as well!

Fortgesetzte Tabelle
Continued Table

Bestellbeispiel // Order example: **A06.0016 T**

Detail A | 1 Halter - 4 Kühlmittelzufuhrarten // 1 Toolholder - 4 types of coolant supply

