

Klemmhalter, Innenbearbeitung, Rundschaft

Rundschaft mit innerer Kühlmittelzufuhr für die Größe A05.
Vier Kühlmittelzufuhrarten je nach Bedarf einstellbar.

Toolholder, Internal Applications, Round Shank

Round shank with through coolant for size A05.
Four different types of through coolant supply can be realized as required.

Anzugsmoment (Schraube) // Tightening torque (screw)

7,0 Nm

Bitte Hinweise im Anhang beachten // Please read add. notes

MASTER (Seite/Page 137)



Legende
Legend **139**



Scan
QR-Code

Oder besuchen Sie // Or Visit
www.simtek.info/cp/1201

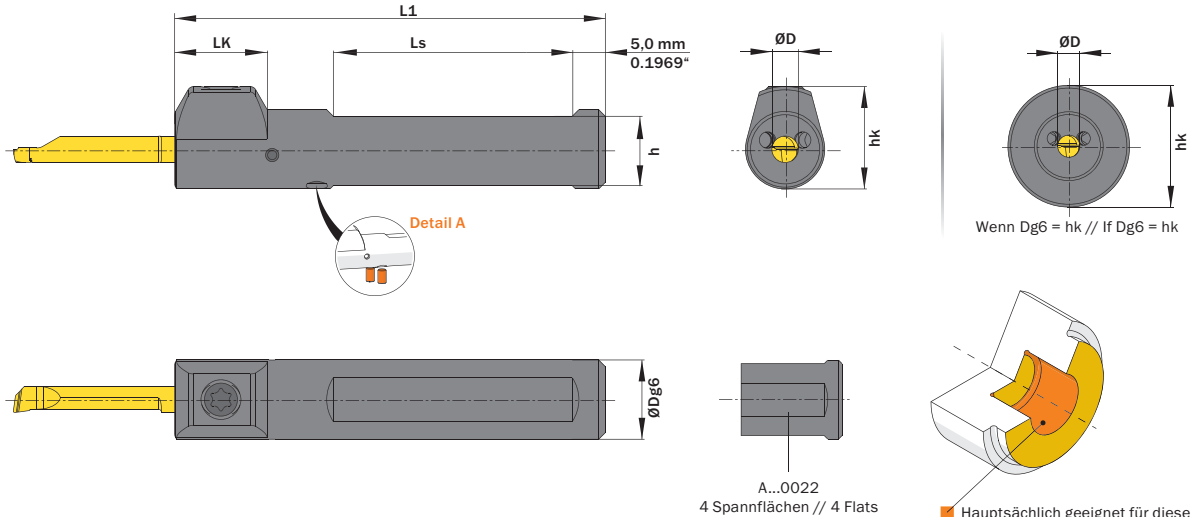

■ Hauptsächlich geeignet für diese Flächen
Mainly designed for these surfaces
■ Je nach Schneidplatte ebenfalls möglich
Also possible depending on insert type

ØD	ØDg6	Artikelnummer Part number	Webcode www.simtek.com/webcode	h	hk	L1	LK	Ls	Anzahl Spannflächen Number of flats	Schraube Screw	Schraubenschlüssel Screw driver	Connectcode www.simtek.com/code
mm	mm			mm	mm	mm	mm	mm				

Fortgesetzte Tabelle
Continued Table

Verwandte Werkzeuge finden Sie auch auf der vorhergehenden Seite!
Related items can be found on the previous page as well!

5,0	12,0	A05.0012 T	AUSZ	10,5	16,0	70,0	14,0	41,0	2	A M6x7,5 T15F	T15F	A05.L A05.R A05.T
5,0	12,7	A05.0.500 T	AUS2	11,2	16,35	70,0	14,0	41,0	2	A M6x7,5 T15F	T15F	A05.L A05.R A05.T inch
5,0	15,875	A05.0.625 T	AZMU	13,88	17,94	75,0	14,0	46,0	2	A M6x7,5 T15F	T15F	A05.L A05.R A05.T inch
5,0	16,0	A05.0016 T	AUTE	14,0	18,0	75,0	14,0	46,0	2	A M6x7,5 T15F	T15F	A05.L A05.R A05.T
5,0	19,05	A05.0.750 T	AUS8	17,05	19,05	110,0	-	81,0	2	A M6x7,5 T15F	T15F	A05.L A05.R A05.T inch
5,0	20,0	A05.0020 T	AUTQ	18,0	20,0	90,0	-	61,0	2	A M6x7,5 T15F	T15F	A05.L A05.R A05.T
5,0	22,0	A05.0022 T	AUTH	20,0	22,0	110,0	-	90,0	4	A M6x7,5 T15F	T15F	A05.L A05.R A05.T
5,0	25,0	A05.0025 T	AUTM	23,0	25,0	110,0	-	90,0	2	A M6x7,5 T15F	T15F	A05.L A05.R A05.T
5,0	25,4	A05.1.000 T	AUTX	23,4	25,4	110,0	-	90,0	2	A M6x7,5 T15F	T15F	A05.L A05.R A05.T inch

Verwandte Werkzeuge finden Sie auch auf der folgenden Seite!
Related items can be found on the following page as well!

Fortgesetzte Tabelle
Continued Table

Bestellbeispiel // Order example: **A05.0016 T**

Detail A | 1 Halter - 4 Kühlmittelzufuhrarten // 1 Toolholder - 4 types of coolant supply

