

Klemmhalter, Innenbearbeitung, Rundschaft

Rundschaft mit innerer Kühlmittelzufuhr für die Größe A04.
Vier Kühlmittelzufuhrarten je nach Bedarf einstellbar.

Toolholder, Internal Applications, Round Shank

Round shank with through coolant for size A04.
Four different types of through coolant supply can be realized as required.

Anzugsmoment (Schraube) // Tightening torque (screw)

7,0 Nm

Bitte Hinweise im Anhang beachten // Please read add. notes

MASTER (Seite/Page 137)



Legende
Legend

139



Scan
QR-Code

Oder besuchen Sie // Or Visit
www.simtek.info/cp/1200

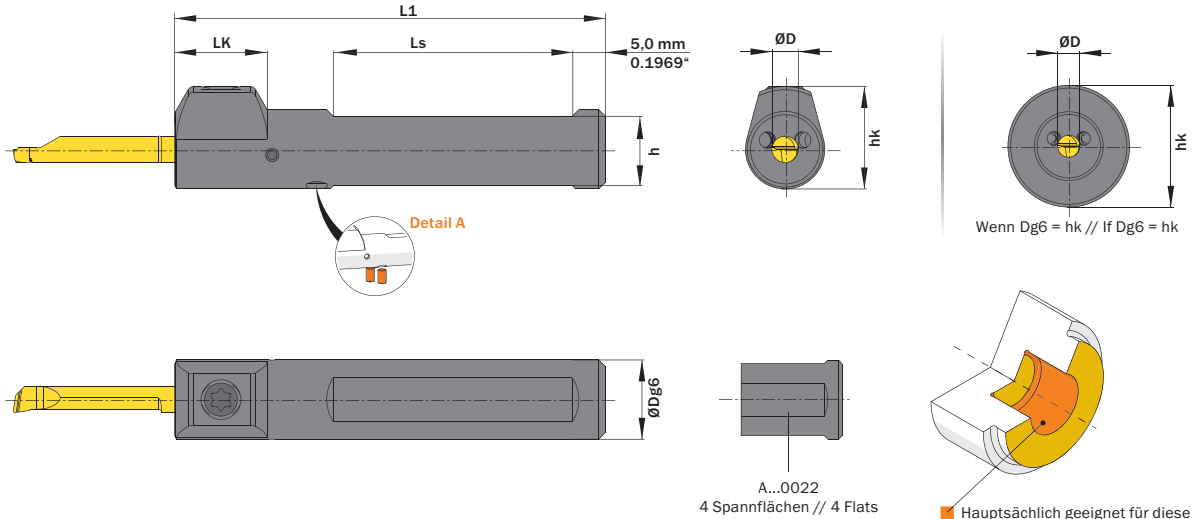

ØD	ØDg6	Artikelnummer Part number	Webcode www.simtek.com/webcode	h	hk	L1	LK	Ls	Anzahl Spannflächen Number of flats	Schraube Screw	Schraubenschlüssel Screw driver	Connectcode www.simtek.com/code
mm	mm			mm	mm	mm	mm	mm				
4,0	12,0	A04.0012 T	AUQY	10,5	15,5	70,0	14,0	41,0	2	AM6x7,5 T15F	T15F	A04.L A04.R A04CL A04C.R A04T
4,0	12,7	A04.0.500 T	A5H9	11,0	15,85	70,0	41,0	41,0	2	AM6x7,5 T15F	T15F	
4,0	15,875	A04.0.625 T	A5H7	11,0	17,44	75,0	14,0	46,0	2	AM6x7,5 T15F	T15F	
4,0	16,0	A04.0016 T	AUQ1	14,0	17,5	75,0	14,0	46,0	2	AM6x7,5 T15F	T15F	
4,0	19,05	A04.0.750 T	AUSA	17,05	19,05	110,0	-	81,0	2	AM6x7,5 T15F	T15F	A04CL A04C.R
4,0	20,0	A04.0020 T	AUSP	18,0	20,0	90,0	-	61,0	2	AM6x7,5 T15F	T15F	
4,0	22,0	A04.0022 T	AUST	20,0	22,0	110,0	-	90,0	4	AM6x7,5 T15F	T15F	A04T
4,0	25,0	A04.0025 T	AUSW	23,0	25,0	110,0	-	90,0	2	AM6x7,5 T15F	T15F	
4,0	25,4	A04.1.000 T	AUSK	23,39	25,4	110,0	-	90,0	2	AM6x7,5 T15F	T15F	

Verwandte Werkzeuge finden Sie auch auf der folgenden Seite!
Related Items can be found on the following page as well!

Fortgesetzte Tabelle
Continued Table

Bestellbeispiel // Order example: **A04.0016 T**

Detail A | 1 Halter - 4 Kühlmittelzufuhrarten // 1 Toolholder - 4 types of coolant supply

