

# Einstecken und Profildrehen

CNC-Konturdrehen.

## Grooving and Profiling

CNC profiling.

Schnittwerte (Start) // Cutting parameters (start)

f (außen/ext.) 0,04 mm/U	f (innen/int.) 0,03 mm/U	Vc Seite/Page 429
-----------------------------	-----------------------------	----------------------

Passende Klemmhalter auf Seite // Suitable toolholders on page  
**323, 324, 325, 326, 327, 328**

SP  
CBN

SP  
HM

R

Legende  
Legend

354

Scan  
QR-Code

Oder besuchen Sie // Or Visit  
[www.simtek.info/cp/309](http://www.simtek.info/cp/309)



Abbildung zeigt / Drawing shows: TE3.0200.04 NR

w ±0,02 mm	R mm	Artikelnummer Part number	Webcode www.simtek.com/webcode	Unsere erste Wahl Our first choice	S mm	tmax mm	Connectcode www.simtek.com/code	
<b>▼ R = 0,05 mm</b>								
1,0	0,05	<b>TE3.0100.005 N R/L</b>	R A1T4 L A41Z	X808 X408	5,45	2,5	R TE3.R.5.3 L TE3.L.5.3 <b>new</b>	
<b>▼ R = 0,2 mm</b>								
1,0	0,2	<b>TE3.0100.02 N R/L</b>	R AUKW L AUKX	X808 X408	5,45	2,5	R TE3.R.5.3 L TE3.L.5.3	
1,5	0,2	<b>TE3.0150.02 N R/L</b>	R AGUC L AJCØ	X800 X400	5,6	5,0	R TE3.R.5.3 L TE3.L.5.3	
2,0	0,2	<b>TE3.0200.02 N R/L</b>	R AAFU L AMG1	X800 X400	5,6	5,0	R TE3.R.5.3 L TE3.L.5.3	
2,388	0,2	<b>TE3.0238.02 N R</b>	A55T	X800 X400	5,6	5,0	<b>TE3.R.5.3</b> <b>new</b>	
2,5	0,2	<b>TE3.0250.02 N R/L</b>	R AQHV L AQHW	X800 X400	5,55	5,0	R TE3.R.5.3 L TE3.L.5.3	
3,0	0,2	<b>TE3.0300.02 N R/L</b>	R AEY1 L AJYY	X800 X400	5,55	5,0	R TE3.R.5.3 L TE3.L.5.3	
3,175	0,2	<b>TE3.0318.02 N R</b>	A55V	X800 X400	5,6	5,0	<b>TE3.R.5.3</b> <b>new</b>	
4,0	0,2	<b>TE3.0400.02 N R/L</b>	R ABXC L AB96	X800 X400	5,6	5,0	R TE3.R.5.3 L TE3.L.5.3	
4,75	0,2	<b>TE3.0475.02 N R</b>	A55X	X800 X400	5,6	5,0	<b>TE3.R.5.3</b> <b>new</b>	
<b>▼ R = 0,4 mm</b>								
2,0	0,4	<b>TE3.0200.04 N R/L</b>	R AQMV L AQMW	X800 X400	5,6	5,0	R TE3.R.5.3 L TE3.L.5.3	
2,5	0,4	<b>TE3.0250.04 N R/L</b>	R AG8Y L AGBH	X800 X400	5,6	5,0	R TE3.R.5.3 L TE3.L.5.3	
3,0	0,4	<b>TE3.0300.04 N R/L</b>	R AQHY L AQHX	X800 X400	5,6	5,0	R TE3.R.5.3 L TE3.L.5.3	
4,0	0,4	<b>TE3.0400.04 N R/L</b>	R ASE2 L ASE1	X800 X400	5,6	5,0	R TE3.R.5.3 L TE3.L.5.3	
<b>▼ R = 0,6 mm</b>								
3,0	0,6	<b>TE3.0300.06 N R/L</b>	R AT61 L AT60	X800 X400	5,6	5,0	R TE3.R.5.3 L TE3.L.5.3	
<b>▼ R = 0,8 mm</b>								
3,0	0,8	<b>TE3.0300.08 N R/L</b>	R AT7T L AT7S	X800 X400	5,6	5,0	R TE3.R.5.3 L TE3.L.5.3	

Bestellbeispiel // Order example: **TE3.0200.02 N R X800** (R = Rechte Ausführung // Right hand version, X800 = Schneidstoff // Grade)

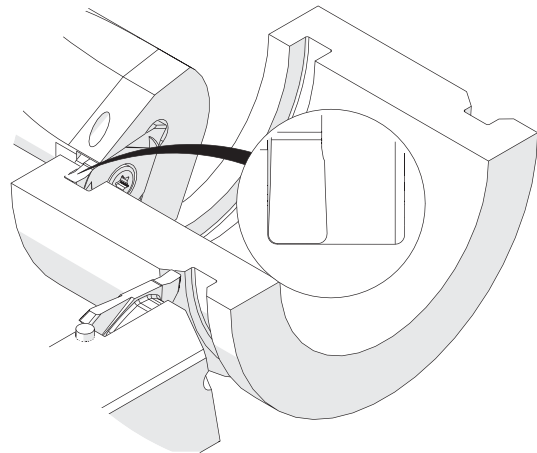
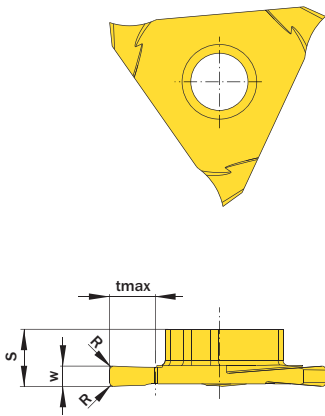

TE3. w, 1/100 mm, 4 Stellen/Digits . R, 1/100 mm, 3 Stellen/Digits Toleranz // Tolerance R/L

Beispielartikelnummer // Example Part number: **TE3.0156.015 XN R** oder/ or **TE3.0156.015 XN L**