

## Kassette „D14“

Für simturn D14-Schneidwerkzeuge. Passend zu Adapter „MOS.STA...“.

## Cassette „D14“

For simturn D14-cutting inserts. Suitable adaptor: „MOS.STA...“.

Anzugsmoment (Schraube) // Tightening torque (screw)

**6,0 Nm**

Bitte Hinweise im Anhang beachten // Please read add. notes

**ALL (Seite/Page 645)**



Legende  
Legend

**650**



Scan  
QR-Code

Oder besuchen Sie // Or Visit  
[www.simtek.info/cp/962](http://www.simtek.info/cp/962)

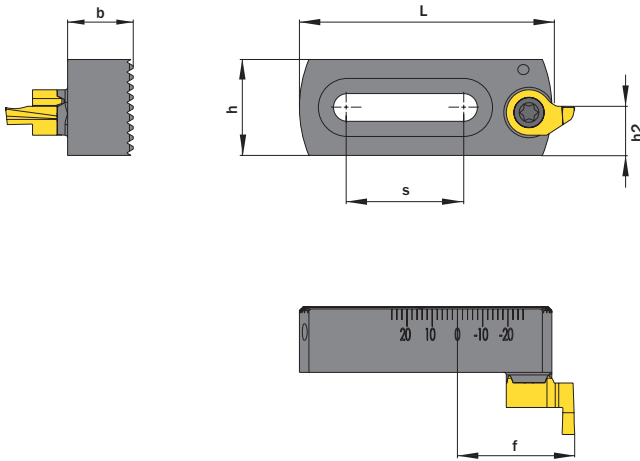

Eine Auswahl passender Schneidplatten finden Sie auf Seite:

**168, 207, 208, 210, 211**

A selection of compatible Cutting Inserts can be found on page:

**168, 207, 208, 210, 211**

Abbildung zeigt / Drawing shows: MOS.STK.D14.A

L	Artikelnummer Part number	Webcode <a href="http://www.simtek.com/webcode">www.simtek.com/webcode</a>	b	f	h	h2	S	Schraube Screw	Schraubenschlüssel Screw driver	Connectcode <a href="http://www.simtek.com/code">www.simtek.com/code</a>
mm			mm	mm	mm	mm	mm			
50,0	<b>MOS.STK.D14.A</b>	AU6Z	13,0	22,67	19,0	9,5	23,0	MM5x13 T20R	T20R	D14   D14.A.R

Bestellbeispiel // Order example: **MOS.STK.D14.A**

simmill AX

simmill PMX

simmill PX

simmill SX

simmill UX

simmill VX

simmill H2

simmill K2

simmill MX

simmill OS

Index