

Nutenstechen

Für allgemeines Nutenstechen und für Sicherungsringnuten.
Geeignet ab Bohrungsdurchmesser 7,0 mm.

Grooving

For general grooving as well as for circlip ring grooving.
For use in bores as of minimum bore diameter 7,0 mm.

Schnittwerte (Start) // Cutting parameters (start)

f	Vc
0,02 mm/U	Seite/Page 429

Passende Klemmhalter auf Seite // Suitable toolholders on page
153, 162, 164

Vergleichbare Werkzeuge auf Seite // Similar tools on page
175



Legende
Legend **213**



Scan
QR-Code

Oder besuchen Sie // Or Visit
www.simtek.info/cp/965

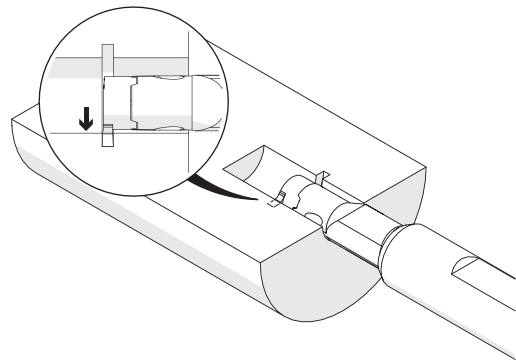
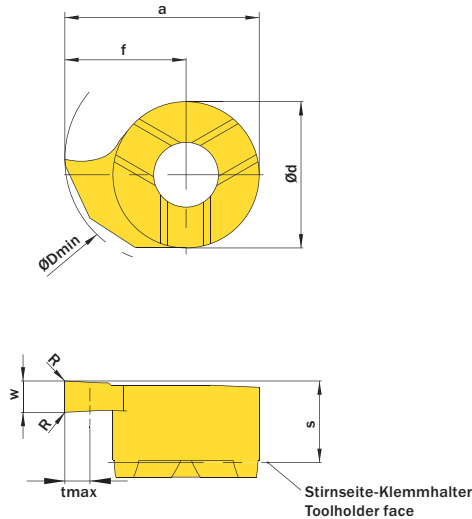

$w^{+0,03}$	Nutnenbreite Nominal width of groove	ØDmin (Min. Bohrung) ØDmin (min. bore)	Artikelnummer Part number	Webcode www.simtek.com/webcode	Unsere erste Wahl Our first choice	a	Ød	f	R	S	tmax	Connectcode www.simtek.com/code
mm	mm	mm			P K M N S	mm	mm	mm	mm	mm	mm	
▼ ØDmin (Min. Bohrung) // ØDmin (min. bore) = 7,0 mm												
1,0	-	7,0	D07.0100.00.07 GR/L	R AU52 L AXA3	X800 X400	6,6	4,8	4,2	-	3,7	1,0	D07
1,5	-	7,0	D07.0150.00.07 GR/L	R AU53 L AXA5	X800 X400	6,6	4,8	4,2	-	3,7	1,0	D07
▼ ØDmin (Min. Bohrung) // ØDmin (min. bore) = 7,8 mm												
1,0	-	7,8	D07.0100.00.08 GR/L	R AU54 L AXA4	X800 X400	7,6	4,8	5,2	-	3,7	2,0	D07
1,5	-	7,8	D07.0150.00.08 GR/L	R AU55 L AXA6	X800 X400	7,6	4,8	5,2	-	3,7	2,0	D07

Verwandte Werkzeuge finden Sie auch auf der folgenden Seite!
Related Items can be found on the following page as well!

Fortgesetzte Tabelle
Continued Table

Bestellbeispiel // Order example: **D07.0150.00.08 GR X800** (R = Rechte Ausführung // Right hand version, X800 = Schneidstoff // Grade)

