

Stechdrehen, Sicherungsringnuten, mit geschliffener Spanformrille

Sicherungsringnuten vgl. DIN 471/472 sowie DIN 983/984, mit Spanformrille.

Grooving, Circlip Ring Grooves, with ground chip form channel

Circlip ring grooves comp. to DIN 471/472 and DIN 983/984, with chip form channel.

Schnittwerte (Start) // Cutting parameters (start)		
f (außen//ext.) 0,04 mm/U	f (innen//int.) 0,03 mm/U	Vc Seite/Page 429

Passende Klemmhalter auf Seite // Suitable toolholders on page
323, 324, 325, 326, 327, 328

SP

HM

R

Legende
Legend **354**

Scan QR-Code

Oder besuchen Sie // Or Visit
www.simtek.info/cp/884

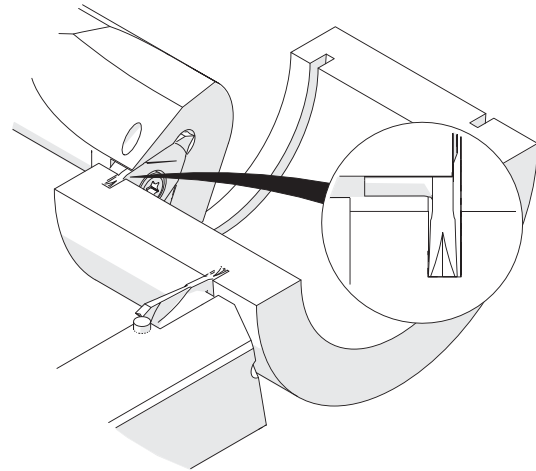
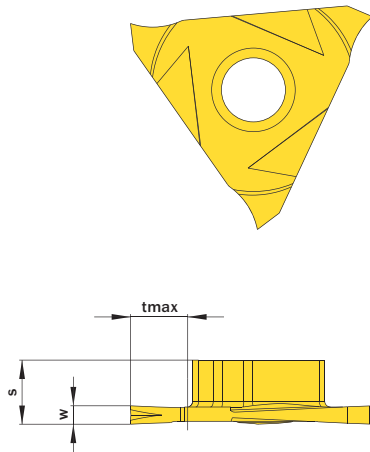

Abbildung zeigt / Drawing shows: TE3.0160.00 GT R

Nennbreite Nominal width of groove	w ^{+0,03} mm	Mit Spanformrille With chip form channel	Artikelnummer Part number	Webcode www.simtek.com/webcode		Unsere erste Wahl Our first choice		S mm	tmax mm	Connectcode www.simtek.com/code			
				P	K	M	N			S	R	L	
1,1	1,2	Ja / Yes	TE3.0110.00 GT R/L	R AT0M	L AT0N	X800	X400	5,6	5,0	R	TE3.R.5.3	L	TE3.L.5.3
1,3	1,4	Ja / Yes	TE3.0130.00 GT R/L	R AT0P	L AT0Q	X800	X400	5,6	5,0	R	TE3.R.5.3	L	TE3.L.5.3
1,6	1,7	Ja / Yes	TE3.0160.00 GT R/L	R AT0S	L AT0T	X800	X400	5,6	5,0	R	TE3.R.5.3	L	TE3.L.5.3
1,85	1,95	Ja / Yes	TE3.0185.00 GT R/L	R AT0U	L AT0V	X800	X400	5,6	5,0	R	TE3.R.5.3	L	TE3.L.5.3
2,15	2,25	Ja / Yes	TE3.0215.00 GT R/L	R AT0W	L AT0X	X800	X400	5,6	5,0	R	TE3.R.5.3	L	TE3.L.5.3

Bestellbeispiel // Order example: **TE3.0185.00 GT R X800** (R = Rechte Ausführung // Right hand version, X800 = Schneidstoff // Grade)