

Gewindedrehen, Trapezgewinde, Teilprofil

Teilprofil für Trapez-Gewinde.

Threading, Trapezoidal Partial Profile

Partial profile for internal trapezoidal-thread.

Schnittwerte (Start) // Cutting parameters (start)
Anzahl Durchgänge // Number of passes 12 - 18
Empf. Zustellungsart // Recom. infeed method Flankenzustellung // Flank infeed (Seite/Page 433)
Vc Seite/Page 429

Passende Klemmhalter auf Seite // Suitable toolholders on page
155, 156, 157, 158, 159, 161, 163, 164

SP HM **Legende 213**

Scan QR-Code Oder besuchen Sie // Or Visit www.simtek.info/cp/825

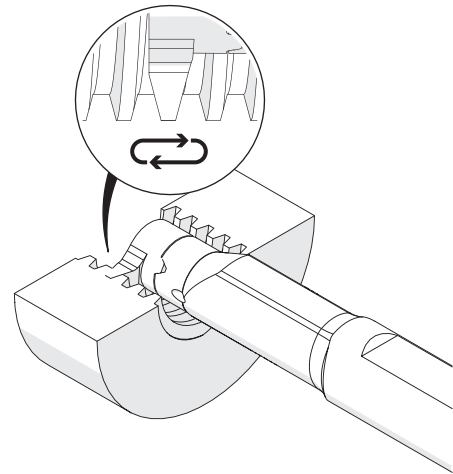
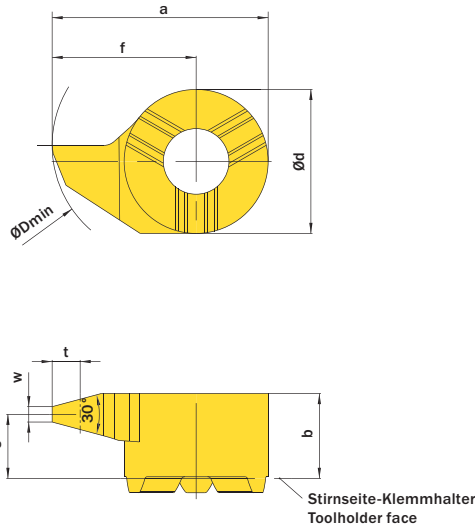

Abbildung zeigt / Drawing shows: D14.1730.01 MR

Ab Gewindegröße As of thread size	t mm	Steigung (von) Pitch (as of) mm	Artikelnummer Part number	Webcode www.simtek.com/webcode	Unsere erste Wahl Our first choice					a mm	b mm	Ød mm	ØDmin (Min. Bohrung) ØDmin (min. bore) mm	f mm	S mm	w mm	Connectcode www.simtek.com/code
					P	K	M	N	S								
▼ Ab Gewindegröße // As of thread size = 12,0																	
12,0	0,9	1,5	D09.TR15.01.09 MR/L	R AWF1	L AWHE	X800	X400		8,6	3,55	6,2	9,0	5,5	3,0	0,47		D09
12,0	1,25	2,0	D09.TR20.01.09 MR/L	R AWF0	L AWHD	X800	X400		8,6	3,55	6,2	9,0	5,5	2,85	0,6		D09
12,0	0,9	1,5	D10.TR15.01.10 MR/L	R ASBH	L ASBG	X800	X400		9,3	3,95	7,0	10,0	5,8	3,32	0,47		D10
▼ Ab Gewindegröße // As of thread size = 14,0																	
14,0	1,75	3,0	D09.TR30.01.09 MR/L	R AWFZ	L AWHC	X800	X400		8,6	3,55	6,2	9,0	5,5	2,25	0,96		D09
14,0	1,25	2,0	D10.TR20.01.10 MR/L	R ASBK	L ASBJ	X800	X400		9,3	3,7	7,0	10,0	5,8	2,91	0,6		D10
14,0	1,75	3,0	D10.TR30.01.10 MR/L	R ASBN	L ASBM	X800	X400		9,3	3,7	7,0	10,0	5,8	2,57	0,96		D10
14,0	0,9	1,5	D11.1015.01 MR/L	R AA9G	L AAQ0	X800	X400		10,7	4,3	8,0	11,0	6,7	3,7	0,47		D11
14,0	1,25	2,0	D11.1220.01 MR/L	R AF6J	L AH27	X800	X400		10,7	4,3	8,0	11,0	6,7	3,5	0,6		D11
▼ Ab Gewindegröße // As of thread size = 16,0																	
16,0	2,25	4,0	D09.TR40.01.10 MR/L	R AWFY	L AWHB	X800	X400		9,6	3,55	6,2	10,0	6,5	2,25	1,33		D09
16,0	2,25	4,0	D10.TR40.01.11 MR/L	R ASBQ	L ASBP	X800	X400		10,3	3,7	7,0	11,0	6,8	2,14	1,33		D10
16,0	1,75	3,0	D11.1730.01 MR/L	R AP1Y	L AMT5	X800	X400		10,7	4,3	8,0	11,0	6,7	3,2	0,96		D11
16,0	2,25	4,0	D11.2240.01 MR/L	R ANXG	L AFT8	X800	X400		10,7	4,0	8,0	11,0	6,7	2,6	1,33		D11
▼ Ab Gewindegröße // As of thread size = 18,0																	
18,0	1,25	2,0	D14.1220.01 MR/L	R AD11	L AFN9	X800	X400		13,5	5,3	9,0	14,0	9,0	4,3	0,6		D14
18,0	1,75	3,0	D14.1730.01 MR/L	R AMAN	L ANQF	X800	X400		13,5	5,3	9,0	14,0	9,0	4,0	0,96		D14
▼ Ab Gewindegröße // As of thread size = 20,0																	
20,0	2,25	4,0	D14.2240.01 MR/L	R AGYM	L AKD9	X800	X400		13,5	5,3	9,0	14,0	9,0	4,0	1,33		D14
20,0	1,25	2,0	D16.1220.01 MR/L	R AGNW	L AAX2	X800	X400		15,2	5,5	11,0	16,0	9,7	4,5	0,6		D16
20,0	1,75	3,0	D16.1730.01 MR/L	R AG99	L AM5S	X800	X400		15,2	5,5	11,0	16,0	9,7	4,3	0,96		D16
▼ Ab Gewindegröße // As of thread size = 22,0																	
22,0	2,75	5,0	D14.2750.01 MR/L	R AJ51	L AA01	X800	X400		13,5	5,3	9,0	14,0	9,0	3,55	1,69		D14
22,0	2,25	4,0	D16.2240.01 MR/L	R ANBP	L ACCX	X800	X400		15,2	5,5	11,0	16,0	9,7	4,0	1,33		D16
22,0	2,75	5,0	D16.2750.01 MR/L	R APG1	L ANCP	X800	X400		15,7	5,5	11,0	16,0	10,2	3,6	1,69		D16
▼ Ab Gewindegröße // As of thread size = 32,0																	
32,0	3,5	6,0	D16.3560.01 MR/L	R AEJX	L APZ5	X800	X400		15,7	5,5	11,0	16,0	10,2	3,3	1,92		D16

Bestellbeispiel // Order example: **D16.2750.01 MR X800** (R = Rechte Ausführung // Right hand version, X800 = Schneidstoff // Grade)