

Halbzeuge, Formstechen

Halbzeuge für komponenten- und kundenspezifische Formeinstiche.

Semi-Finished-Insert, Profiling

Semi-finished-insert for component and client specific forms.

Passende Klemmhalter auf Seite // Suitable toolholders on page
414, 415



SP Legende
HM Legend

423

Scan QR-Code

Oder besuchen Sie // Or Visit
www.simtek.info/cp/727

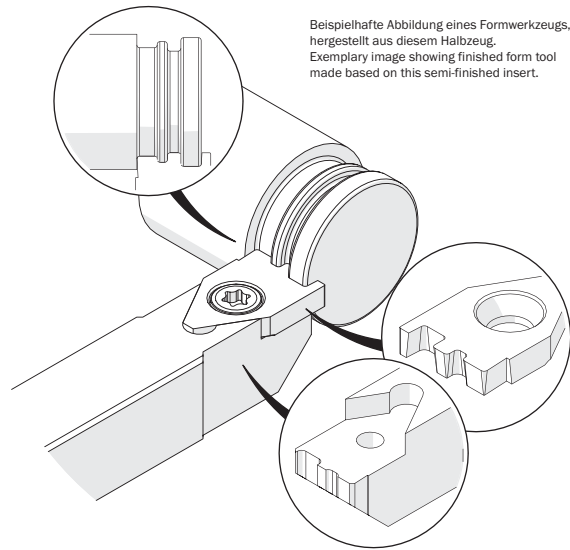
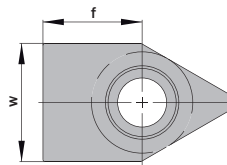
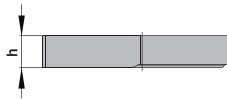

Beispielhafte Abbildung eines Formwerkzeugs, hergestellt aus diesem Halbzeug.
 Exemplary image showing finished form tool made based on this semi-finished insert.

Abbildung zeigt / Drawing shows: F10.1109.30 M

w mm	h ^{+0,05} mm	Artikelnummer Part number	Webcode www.simtek.com/webcode	Unsere erste Wahl Our first choice P K M N S	f mm	Connectcode www.simtek.com/code
▼ Connectcode = TF10.A.30 TF10.B.30						
11,1	2,95	F10.1109.30 M	ASAU	X800 X400	9,3	TF10.A.30 TF10.B.30
▼ Connectcode = TF10.A.45 TF10.B.45						
11,1	4,4	F10.1109.45 M	ASAY	X800 X400	9,3	TF10.A.45 TF10.B.45

Bestellbeispiel // Order example: **F10.1109.45 M GF25** (GF25 = Schneidstoff // Grade)