

## UN-Gewindefräsen, Vollprofil

Fräsen von UN-Gewinden, Vollprofil.

## Thread milling, UN Full Profile

Thread milling of UN-threads, full profile.

Schnittwerte (Start) // Cutting parameters (start)

fzm	hmax	Vc
<b>0,03 mm</b>	<b>0,04 mm</b>	<b>Seite/Page 638</b>

Passende Klemmhalter auf Seite // Suitable toolholders on page

**529, 530, 531, 532, 533**

Bitte Hinweise im Anhang beachten // Please read add. notes

**ALL (Seite/Page 645), H03 (Seite/Page 647)**



**SP** Legende  
**HM** Legend

**650**



Scan QR-Code

Oder besuchen Sie // Or Visit  
[www.simtek.info/cp/880](http://www.simtek.info/cp/880)

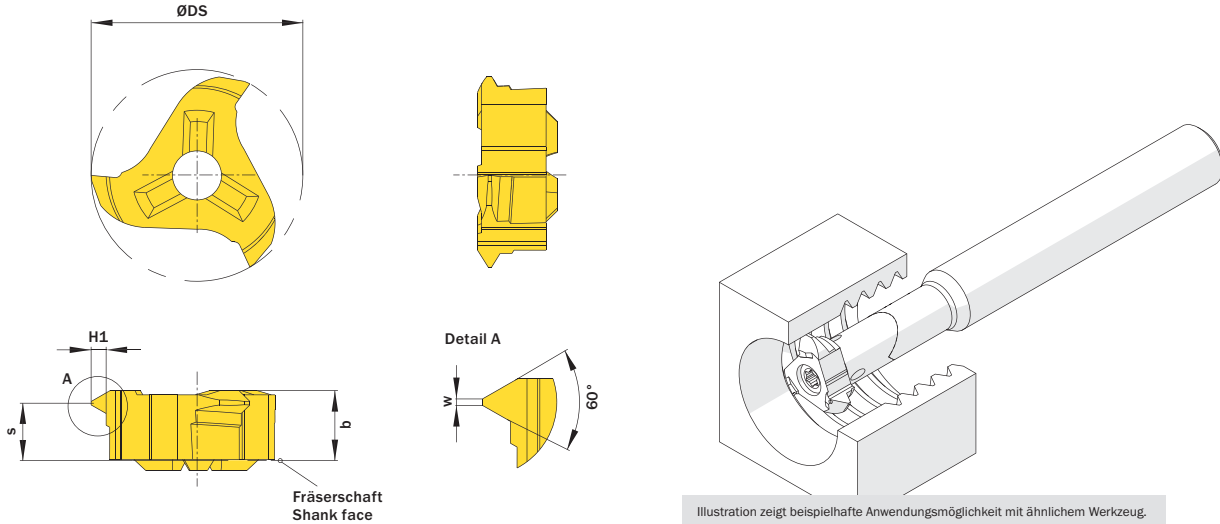

Illustration zeigt beispielhafte Anwendungsmöglichkeit mit ähnlichem Werkzeug.  
 Image shows exemplary application possibility with similar tool.

Abbildung zeigt / Drawing shows: U18.UN11.02 M

Gang/Zoll Threads/inch	Artikelnummer Part number	Webcode <a href="http://www.simtek.com/webcode">www.simtek.com/webcode</a>	Unsere erste Wahl Our first choice		b	H1	S	ØDS	w	Anzahl Schneiden Number of cutting edges	Connectcode <a href="http://www.simtek.com/code">www.simtek.com/code</a>
			P M K N S								
6	<b>U18.UN06.02 M</b>	AS7Q	X800	GT42	5,85	2,291	4,2	17,7	0,53	3	UD09.0 UD12.0 UD13.0
7	<b>U18.UN07.02 M</b>	A4YF	X800	GT42	5,85	1,96	4,2	17,7	0,45	3	UD09.0 UD12.0 UD13.0 <b>new</b>
8	<b>U18.UN08.02 M</b>	AS04	X800	GT42	5,85	1,718	4,4	17,7	0,4	3	UD09.0 UD12.0 UD13.0
10	<b>U18.UN10.02 M</b>	AS03	X800	GT42	5,85	1,375	4,6	17,7	0,32	3	UD09.0 UD12.0 UD13.0
11	<b>U18.UN11.02 M</b>	AS02	X800	GT42	5,85	1,249	4,8	17,7	0,29	3	UD09.0 UD12.0 UD13.0
12	<b>U18.UN12.02 M</b>	AS01	X800	GT42	5,85	1,146	4,8	17,7	0,27	3	UD09.0 UD12.0 UD13.0
14	<b>U18.UN14.02 M</b>	AS00	X800	GT42	5,85	0,981	5,0	17,7	0,23	3	UD09.0 UD12.0 UD13.0
16	<b>U18.UN16.02 M</b>	AS0Z	X800	GT42	5,85	0,859	5,0	17,7	0,2	3	UD09.0 UD12.0 UD13.0
<b>18</b>	<b>U18.UN18.02 M</b>	<b>AS0Y</b>	<b>X800</b>	<b>GT42</b>	<b>5,85</b>	<b>0,763</b>	<b>5,1</b>	<b>17,7</b>	<b>0,18</b>	<b>3</b>	<b>UD09.0 UD12.0 UD13.0</b>
20	<b>U18.UN20.02 M</b>	AS0X	X800	GT42	5,85	0,687	5,2	17,7	0,16	3	UD09.0 UD12.0 UD13.0
24	<b>U18.UN24.02 M</b>	AS0W	X800	GT42	5,85	0,572	5,2	17,7	0,13	3	UD09.0 UD12.0 UD13.0

Bestellbeispiel // Order example: **U18.UN08.02 M X800** (X800 = Schneidstoff // Grade)