

Fräsen von Sicherungsringnuten mit Fassung

Fräsen von Sicherungsringnuten mit Nutaußenkantenfasung.
 Geeignet ab Bohrungsdurchmesser 22,0 mm.

Circlip Ring Groove Milling with chamfering

Circlip ring groove milling with chamfering.
 For use in minimum bore diameter 22,0 mm.

Schnittwerte (Start) // Cutting parameters (start)		
fzm	hmax	Vc
0,04 mm	0,05 mm	Seite/Page 638

Passende Klemmhalter auf Seite // Suitable toolholders on page
556, 557, 558, 559, 560, 561, 562, 563, 564

Bitte Hinweise im Anhang beachten // Please read add. notes
ALL (Seite/Page 645), H01 (Seite/Page 646)



SP Legende
HM Legend

650



Scan
 QR-Code

Oder besuchen Sie // Or Visit
www.simtek.info/cp/419

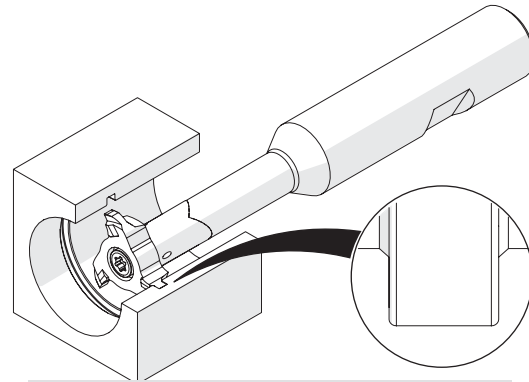
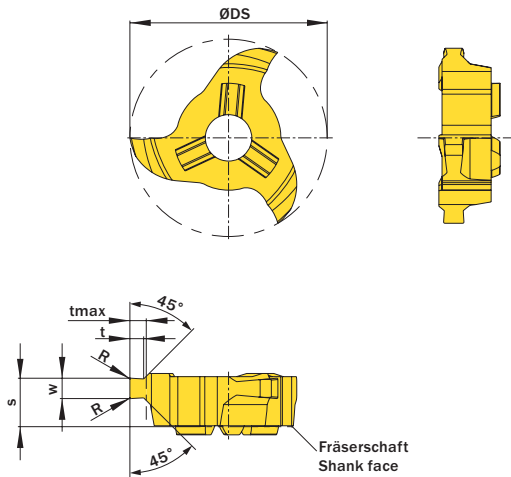

Illustration zeigt beispielhafte Anwendungsmöglichkeit mit ähnlichem Werkzeug.
 Image shows exemplary application possibility with similar tool.

Abbildung zeigt / Drawing shows: V22.2215.35 F

w ^{-0,02}	Nutennbreite Nominal width of groove	R	ØDmin (Min. Bohrung) ØDmin (min. bore)	Artikelnummer Part number	Webcode www.simtek.com/webcode	Unsere erste Wahl Our first choice	t	tmax	S	ØDS	Anzahl Schneiden Number of cutting edges	Connectcode www.simtek.com/code
mm	mm	mm	mm			P M K N S	mm	mm	mm	mm		
1,21	1,1	-	22,0	V22.1105.30 F	ADTP	X800 G742	0,49	0,5	5,1	21,7	3	VD11.3 VD11.5 VD12.0 VD12.7 VD13.5 VD14.0 VD14.3 VD15.0 VD16.0
1,41	1,3	-	22,0	V22.1307.30 F	AJDV	X800 G742	0,67	0,7	5,2	21,7	3	
1,41	1,3	-	22,0	V22.1308.30 F	ADZF	X800 G742	0,83	0,85	5,2	21,7	3	
1,71	1,6	-	22,0	V22.1609.35 F	AKYN	X800 G742	0,83	0,85	5,1	21,7	3	
1,71	1,6	-	22,0	V22.1610.35 F	AKAE	X800 G742	0,97	1,0	5,1	21,7	3	
1,96	1,85	0,15	22,0	V22.1812.35 F	AA3W	X800 G742	1,23	1,25	5,2	21,7	3	
2,26	2,15	0,15	22,0	V22.2215.35 F	APWV	X800 G742	1,47	1,5	5,3	21,7	3	
2,76	2,65	0,15	22,0	V22.2616.45 F	AAAZ	X800 G742	1,47	1,5	5,1	21,7	3	
2,76	2,65	0,15	22,0	V22.2617.45 F	AEW7	X800 G742	1,72	1,75	5,1	21,7	3	
3,26	3,15	0,2	22,0	V22.3118.45 F	AFJ7	X800 G742	1,72	1,75	5,3	21,7	3	
4,26	4,15	0,2	22,0	V22.4120.55 F	AD5S	X800 G742	1,97	2,0	5,3	21,7	3	
4,26	4,15	0,2	22,0	V22.4125.55 F	AE8V	X800 G742	2,47	2,5	5,3	21,7	3	

Bestellbeispiel // Order example: **V22.1609.35 F X800** (X800 = Schneidstoff // Grade)