

Axialstechen

Für die Herstellung von Axialnuten.

Face Grooving

For face grooves in different widths.

Schnittwerte (Start) // Cutting parameters (start)

f	Vc
0,04 mm/U	Seite/Page 429

Passende Klemmhalter auf Seite // Suitable toolholders on page
361, 362, 363, 364, 365, 367

SP

HM

R

Legende
Legend **389**

Scan
QR-Code Oder besuchen Sie // Or Visit
www.simtek.info/cp/509

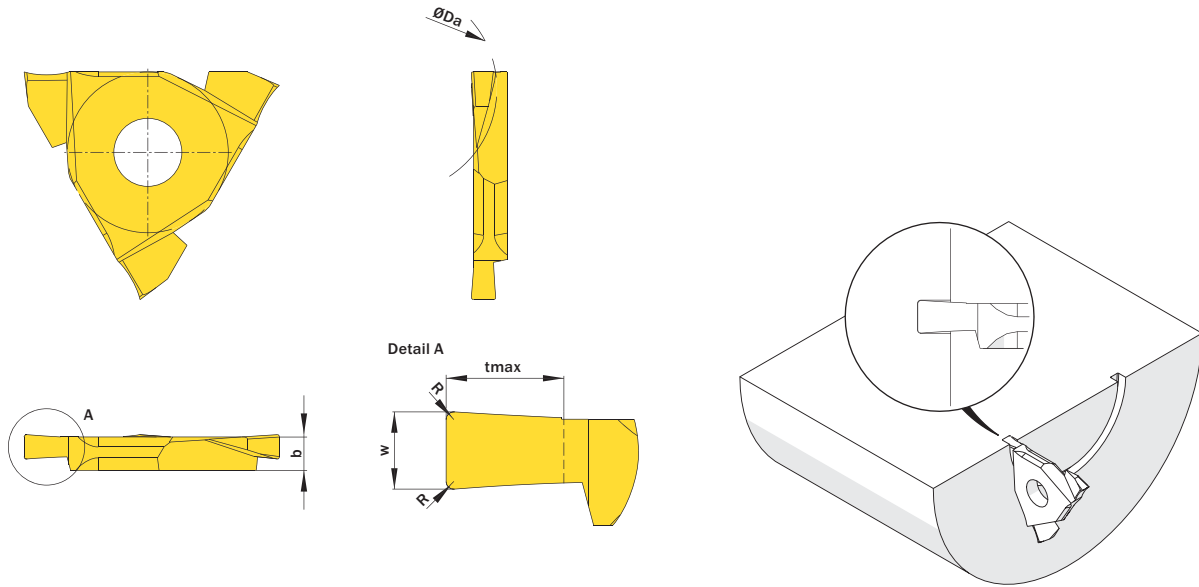

Abbildung zeigt / Drawing shows: E12.3020.02 A R

w ±0,02 mm	Artikelnummer Part number	Webcode www.simtek.com/webcode	Unsere erste Wahl Our first choice	b mm	ØDa mm	R mm	tmax mm	Connectcode www.simtek.com/code
1,5	E12.2015.02 A R/L	R AM85 L AMEV	X800 X400	2,7	30,0	0,2	2,0	E12.B2
2,0	E12.3020.02 A R/L	R ADEQ L APQJ	X800 X400	2,7	30,0	0,2	3,0	E12.B2
3,0	E12.3030.02 A R/L	R ADK0 L AK9X	X800 X400	3,7	30,0	0,2	3,0	E12.C3

Bestellbeispiel // Order example: **E12.3020.02 A R X800** (R = Rechte Ausführung // Right hand version, X800 = Schneidstoff // Grade)

simturn AX
simturn DX
simturn PX
simturn H2
simturn K2
simturn C4
simturn GX
simturn E3
simturn E12
simturn FX
simturn Decolletage
simturn OA
Index