

# Einstecken und Profildrehen

Geeignet ab Bohrungsdurchmesser 11,0 mm.

## Grooving and Profiling

For use in bores as of minimum bore diameter 11,0 mm.

Schnittwerte (Start) // Cutting parameters (start)	
f	Vc
0,02 mm/U	Seite/Page 429

Passende Klemhalter auf Seite // Suitable toolholders on page  
**156, 158, 161, 164**

SP

HM

R

Legende  
Legend

213

Scan  
QR-Code

Oder besuchen Sie // Or Visit  
[www.simtek.info/cp/845](http://www.simtek.info/cp/845)



Abbildung zeigt / Drawing shows: D14.0200.02 NR

w <sup>+0,03</sup>	R	Artikelnummer Part number	Webcode <a href="http://www.simtek.com/webcode">www.simtek.com/webcode</a>	Unsere erste Wahl Our first choice	a	Ød	ØDmin (Min. Bohrung) ØDmin (min. bore)	f	s	tmax	Connectcode <a href="http://www.simtek.com/code">www.simtek.com/code</a>
mm	mm		<a href="http://www.simtek.com/webcode">www.simtek.com/webcode</a>	P K M N S	mm	mm	mm	mm	mm	mm	<a href="http://www.simtek.com/code">www.simtek.com/code</a>

◀ Fortgesetzte Tabelle Continued Table      Verwandte Werkzeuge finden Sie auch auf der vorhergehenden Seite! Related items can be found on the previous page as well!

▼ ØDmin (Min. Bohrung) // ØDmin (min. bore) = 11,0 mm													
1,5	0,2	D10.0150.02.11 NR/L	R AC7X	L AFDW	X800	X400	10,3	7,0	11,0	6,8	3,9	2,8	D10
2,0	0,2	D10.0200.02.11 NR/L	R AFDH	L AFVF	X800	X400	10,3	7,0	11,0	6,8	3,9	2,8	D10
▼ ØDmin (Min. Bohrung) // ØDmin (min. bore) = 12,0 mm													
1,5	0,2	D10.0150.02.12 NR/L	R AKG7	L AHN7	X800	X400	10,9	7,0	12,0	7,4	3,9	3,4	D10
2,0	0,2	D10.0200.02.12 NR/L	R ANQ8	L APHA	X800	X400	10,9	7,0	12,0	7,4	3,9	3,4	D10
▼ ØDmin (Min. Bohrung) // ØDmin (min. bore) = 14,0 mm													
0,787	0,2	D14.0078.02 NR/L	R AB9B	L AKSV	X800	X400	13,5	9,0	14,0	9,0	5,3	4,0	D14
1,168	0,2	D14.0117.02 NR/L	R AACC	L AKHN	X800	X400	13,5	9,0	14,0	9,0	5,3	4,0	D14 <span style="font-size: 8px;">new</span>
1,5	0,2	D14.0150.02 NR/L	R AAHD	L ABEJ	X800	X400	13,5	9,0	14,0	9,0	5,3	4,0	D14 <span style="font-size: 8px;">inch</span>
1,575	0,2	D14.0157.02 NR/L	R AMQ3	L ABFX	X800	X400	13,5	9,0	14,0	9,0	5,3	4,0	D14 <span style="font-size: 8px;">inch</span>
1,979	0,2	D14.0198.02 NR/L	R APT4	L AA5X	X800	X400	13,5	9,0	14,0	9,0	5,3	4,0	D14 <span style="font-size: 8px;">inch</span>
2,0	0,2	D14.0200.02 NR/L	R AC2N	L APKA	X800	X400	13,5	9,0	14,0	9,0	5,3	4,0	D14
2,5	0,2	D14.0250.02 NR/L	R AXZA	L AXZB	X800	X400	13,5	9,0	14,0	9,0	5,3	4,0	D14
3,18	0,2	D14.0318.02 NR/L	R AKAH	L AK9V	X800	X400	13,5	9,0	14,0	9,0	5,3	4,0	D14 <span style="font-size: 8px;">inch</span>
▼ ØDmin (Min. Bohrung) // ØDmin (min. bore) = 16,0 mm													
1,5	0,2	D14.0150.02.16 NR/L	R AF0F	L AD21	X800	X400	15,0	9,0	16,0	10,5	5,2	5,5	D14
2,0	0,2	D14.0200.02.16 NR/L	R AMEQ	L ACFH	X800	X400	15,0	9,0	16,0	10,5	5,2	5,5	D14
2,5	0,2	D14.0250.02.16 NR/L	R APQF	L AN8D	X800	X400	15,0	9,0	16,0	10,5	5,2	5,5	D14
3,0	0,2	D14.0300.02.16 NR/L	R AD8X	L ANVS	X800	X400	15,0	9,0	16,0	10,5	5,2	5,5	D14
▼ ØDmin (Min. Bohrung) // ØDmin (min. bore) = 17,0 mm													
2,388	0,2	D14.0238.02 NR/L	R AD4A	L AM2Z	X800	X400	16,0	9,0	17,0	11,5	5,5	6,5	D14 <span style="font-size: 8px;">new</span>

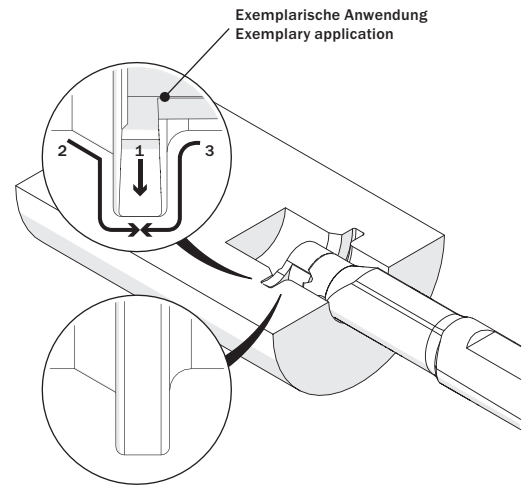
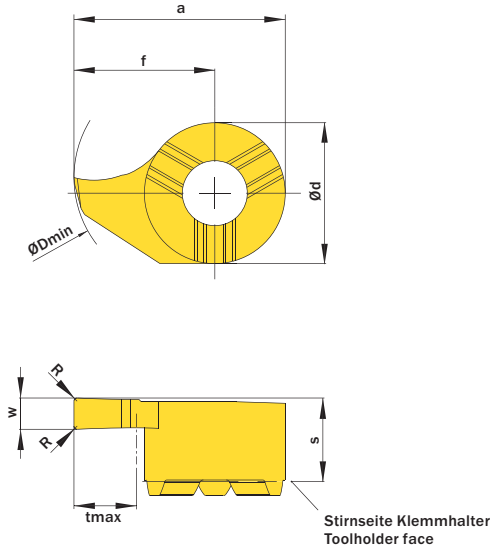
Verwandte Werkzeuge finden Sie auch auf der folgenden Seite! Related items can be found on the following page as well!

Fortgesetzte Tabelle Continued Table ▶

Bestellbeispiel // Order example: **D14.0250.02 NR X800** (R = Rechte Ausführung // Right hand version, X800 = Schneidstoff // Grade)