

# Stechdrehen, Sicherungsringnuten

Sicherungsringnuten vgl. DIN 471/472 sowie DIN 983/984.

## Grooving, circlip ring grooves

Circlip ring grooves comp. to DIN 471/472 and DIN 983/984.

Schnittwerte (Start) // Cutting parameters (start)		
f (außen//ext.) 0,04 mm/U	f (innen//int.) 0,03 mm/U	Vc Seite/Page 429

Passende Klemmhalter auf Seite // Suitable toolholders on page  
**323, 324, 325, 326, 327, 328**

**SP**  
**HM**  
**R**

Legende  
Legend **354**

Scan  
QR-Code

Oder besuchen Sie // Or Visit  
[www.simtek.info/cp/308](http://www.simtek.info/cp/308)



Abbildung zeigt / Drawing shows: TE3.0215.00 GR

Nennbreite Nominal width of groove	w <sup>+0,03</sup> mm	Artikelnummer Part number	Webcode www.simtek.com/webcode	Unsere erste Wahl Our first choice				S mm	tmax mm	Connectcode www.simtek.com/code
				P	K	M	S			
0,5	0,53	TE3.0050.00 G R/L	R AH0J L AF84	X800	X400			5,45	1,43	R TE3.R.5.3 L TE3.L.5.3
0,6	0,63	TE3.0060.00 G R/L	R ADA6 L ADCK	X800	X400			5,45	1,68	R TE3.R.5.3 L TE3.L.5.3
0,7	0,73	TE3.0070.00 G R/L	R AJ4V L AAUT	X800	X400			5,45	1,93	R TE3.R.5.3 L TE3.L.5.3
0,8	0,83	TE3.0080.00 G R/L	R APHD L ADJM	X800	X400			5,45	2,18	R TE3.R.5.3 L TE3.L.5.3
0,9	0,93	TE3.0090.00 G R/L	R AGBW L ANNB	X800	X400			5,45	2,43	R TE3.R.5.3 L TE3.L.5.3
1,0	1,03	TE3.0100.00 G R/L	R AFBT L AKEK	X800	X400			5,45	2,68	R TE3.R.5.3 L TE3.L.5.3
1,1	1,2	TE3.0110.00 G R/L	R AP21 L AJJB	X800	X400			5,6	5,0	R TE3.R.5.3 L TE3.L.5.3
1,1	1,2	TE3.0110.31 G R/L	R AQBUL AQBS	X800	X400			5,6	3,1	R TE3.R.5.3 L TE3.L.5.3
1,17	1,31	TE3.0117.00 GR	A4XX	X800	X400			5,6	5,0	TE3.R.5.3 <small>NEW inch</small>
1,3	1,4	TE3.0130.00 G R/L	R AHV0 L AD91	X800	X400			5,6	5,0	R TE3.R.5.3 L TE3.L.5.3
1,6	1,7	TE3.0160.00 G R/L	R AD0B L AH1Z	X800	X400			5,6	5,0	R TE3.R.5.3 L TE3.L.5.3
1,85	1,95	TE3.0185.00 G R/L	R APGF L AMV5	X800	X400			5,6	5,0	R TE3.R.5.3 L TE3.L.5.3
2,15	2,25	TE3.0215.00 G R/L	R AB92 L AKUE	X800	X400			5,6	5,0	R TE3.R.5.3 L TE3.L.5.3
2,65	2,75	TE3.0265.00 G R/L	R AKW4 L ABJZ	X800	X400			5,6	5,0	R TE3.R.5.3 L TE3.L.5.3
3,15	3,25	TE3.0315.00 G R/L	R AJQN L AHE6	X800	X400			5,6	5,0	R TE3.R.5.3 L TE3.L.5.3
4,15	4,25	TE3.0415.00 G R/L	R AFAK L AE23	X800	X400			5,6	5,0	R TE3.R.5.3 L TE3.L.5.3
5,15	5,25	TE3.0515.00 G R/L	R AE14 L AF57	X800	X400			5,6	5,0	R TE3.R.5.3 L TE3.L.5.3

Bestellbeispiel // Order example: **TE3.0130.00 G R X800** (R = Rechte Ausführung // Right hand version, X800 = Schneidstoff // Grade)

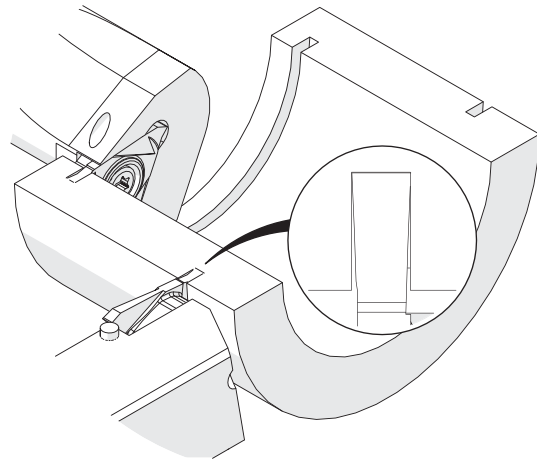
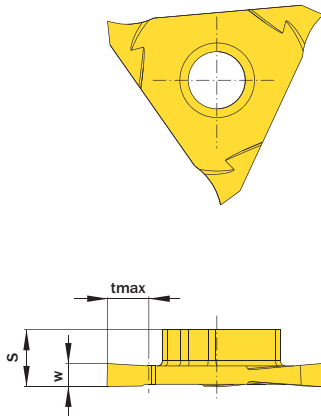

TE3. w, 1/100 mm, 4 Stellen/Digits . R, 1/100 mm, 3 Stellen/Digits Toleranz // Tolerance R/L  
 Beispielartikelnummer // Example Part number: **TE3.0156.015 XN R** oder/ or **TE3.0156.015 XN L**

simturn AX  
simturn DX  
simturn PX  
simturn H2  
simturn K2  
simturn C4  
simturn GX  
simturn E3  
simturn E12  
simturn FX  
simturn Decolletage  
simturn OA  
Index