

# Nutenstechen

Für allgemeines Nutenstechen und für Sicherungsringnuten.  
Geeignet ab Bohrungsdurchmesser 16,0 mm.

# Grooving

For general grooving as well as for circlip ring grooving.  
For use in bores as of minimum bore diameter 16,0 mm.

Schnittwerte (Start) // Cutting parameters (start)

f **0,02 mm/U** Vc **Seite/Page 429**

Passende Klemmhalter auf Seite // Suitable toolholders on page **159, 163**

Vergleichbare Werkzeuge auf Seite // Similar tools on page **175**



**SP** **SP**  
**CBN** **HM**

**R** Legende **213**  
Legend

Scan QR-Code Oder besuchen Sie // Or Visit [www.simtek.info/cp/842](http://www.simtek.info/cp/842)



Abbildung zeigt / Drawing shows: D16.0200.00 G R

w <sup>+0,03</sup>	Nutnenbreite Nominal width of groove	ØDmin (Min. Bohrung) ØDmin (min. bore)	Artikelnummer Part number	Webcode www.simtek.com/webcode	Unsere erste Wahl Our first choice	a	Ød	f	R	S	tmax	Connectcode www.simtek.com/code
mm	mm	mm			P K M N S	mm	mm	mm	mm	mm	mm	

Fortgesetzte Tabelle  
Continued Table

Verwandte Werkzeuge finden Sie auch auf der vorhergehenden Seite!  
Related items can be found on the previous page as well!

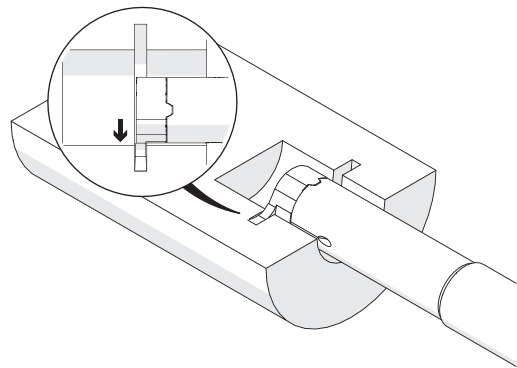
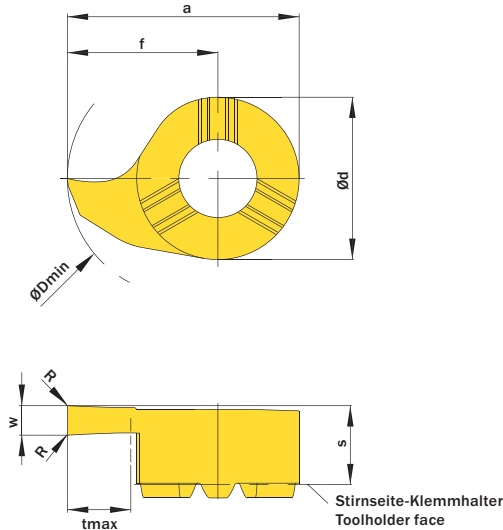
0,73	0,7	16,0	<b>D16.0070.00 ZR/L</b>	R AF7C L AN2X <u>X800</u> <u>X400</u>	15,7	11,0	10,2	-	5,2	1,2	D16
0,787	-	16,0	<b>D16.0078.00 ZR/L</b>	R AMHC L AHKC <u>X800</u> <u>X400</u>	15,7	11,0	10,2	-	5,2	1,3	D16 <span style="float:right">inch</span>
0,83	0,8	16,0	<b>D16.0080.00 ZR/L</b>	R AATC L AFUU <u>X800</u> <u>X400</u>	15,7	11,0	10,2	-	5,2	1,3	D16
0,93	0,9	16,0	<b>D16.0090.00 ZR/L</b>	R ADHV L ABYM <u>X800</u> <u>X400</u>	15,7	11,0	10,2	-	5,2	1,5	D16
1,0	1,0	16,0	<b>D16.0100.00 ZR/L</b>	R AHE1 L AMU9 <u>X800</u> <u>X400</u>	15,7	11,0	10,2	-	5,2	1,3	D16 <span style="float:right">new</span>
1,2	1,1	16,0	<b>D16.0110.00 GR/L</b>	R AKCH L AGF2 <u>X800</u> <u>X400</u>	15,7	11,0	10,2	-	5,4	4,3	D16
1,4	1,3	16,0	<b>D16.0130.00 GR/L</b>	R AEQ6 L ADJ0 <u>X800</u> <u>X400</u>	15,7	11,0	10,2	-	5,4	4,3	D16
1,5	-	16,0	<b>D16.0150.00 GR/L</b>	R AEX2 L ACK6 <u>X800</u> <u>X400</u>	15,7	11,0	10,2	-	5,4	4,3	D16
<b>1,575</b>	<b>-</b>	<b>16,0</b>	<b>D16.0157.00 GR/L</b>	R APGQ L AHAE <u>X800</u> <u>X400</u>	<b>15,7</b>	<b>11,0</b>	<b>10,2</b>	<b>-</b>	<b>5,4</b>	<b>4,3</b>	<b>D16</b> <span style="float:right">inch</span>
1,7	1,6	16,0	<b>D16.0160.00 GR/L</b>	R ANNC L AGBT <u>X800</u> <u>X400</u>	15,7	11,0	10,2	-	5,4	4,3	D16
2,0	-	16,0	<b>D16.0200.00 GR/L</b>	R ACXX L APFT <u>X800</u> <u>X400</u>	15,7	11,0	10,2	-	5,4	4,3	D16
2,5	-	16,0	<b>D16.0250.00 GR/L</b>	R AAMN L AA16 <u>X800</u> <u>X400</u>	15,7	11,0	10,2	-	5,4	4,3	D16
3,0	-	16,0	<b>D16.0300.00 GR/L</b>	R AHSW L AHXD <u>X800</u> <u>X400</u>	15,7	11,0	10,2	-	5,4	4,3	D16
3,5	-	16,0	<b>D16.0350.00 GR/L</b>	R ADH9 L AFEH <u>X800</u> <u>X400</u>	15,7	11,0	10,2	-	5,4	4,3	D16
4,0	-	16,0	<b>D16.0400.00 GR/L</b>	R ACJ0 L AE9X <u>X800</u> <u>X400</u>	15,7	11,0	10,2	-	5,4	4,3	D16

Verwandte Werkzeuge finden Sie auch auf der folgenden Seite!  
Related items can be found on the following page as well!

Fortgesetzte Tabelle  
Continued Table

Bestellbeispiel // Order example: **D16.0150.00 GR X800** (R = Rechte Ausführung // Right hand version, X800 = Schneidstoff // Grade)



D16. w. 1./100 mm, 4 Stellen/Digits | R. 1./100 mm, 3 Stellen/Digits | Toleranz // Tolerance R/L

Beispielartikelnummer // Example Part number: **D16.0156.015 XNR** oder/for **D16.0156.015 XNL**