

Stechen, schmale Sicherungsringnuten

Sicherungsringnuten, vgl. DIN 471/472 sowie DIN 983/984.

Grooving, Circlip Ring Grooves, slim widths

Circlip ring grooves comp. to DIN 471/472 and DIN 983/984.

Schnittwerte (Start) // Cutting parameters (start)

f	Vc
0,04 mm/U	Seite/Page 429

Passende Klemmhalter auf Seite // Suitable toolholders on page

361, 362, 363, 364, 365, 367, 368



SP Legende
HM Legend

389

Scan QR-Code

Oder besuchen Sie // Or Visit
www.simtek.info/cp/498

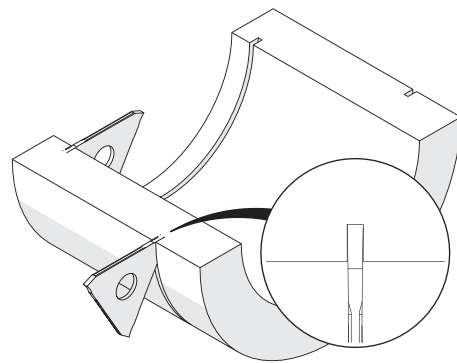
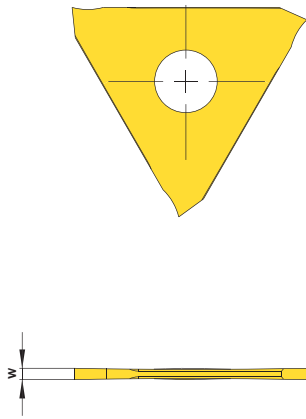

Abbildung zeigt / Drawing shows: E12.0100.00 H

Nennbreite Nominal width of groove mm	Artikelnummer Part number	Webcode www.simtek.com/webcode	Unsere erste Wahl Our first choice	w ^{+0,03} mm		Connectcode www.simtek.com/code
				P	K M N S	
0,5	E12.0050.00 H	AM9A	X808	X408	0,53	E12.A1
0,6	E12.0060.00 H	ABMF	X808	X408	0,63	E12.A1
0,7	E12.0070.00 H	AHDK	X808	X408	0,73	E12.A1
0,8	E12.0080.00 H	AKMH	X808	X408	0,83	E12.A1
0,9	E12.0090.00 H	AA2Z	X808	X408	0,93	E12.A1
1,0	E12.0100.00 H	APFD	X808	X408	1,03	E12.A1 E12.A2

Bestellbeispiel // Order example: **E12.0100.00 H X808** (X808 = Schneidstoff // Grade)