

Axialeinstiche in Bohrungen, Vollradius

Geeignet ab Bohrungsdurchmesser 14,0 mm.

Face Grooving in bores, Full Radius

For use in bores as of minimum bore diameter 14,0 mm.

Schnittwerte (Start) // Cutting parameters (start)

f	Vc
0,02 mm/U	Seite/Page 429

Passende Klemmhalter auf Seite // Suitable toolholders on page
165, 166, 167



Legende
Legend **213**

Scan
QR-Code

Oder besuchen Sie // Or Visit
www.simtek.info/cp/819

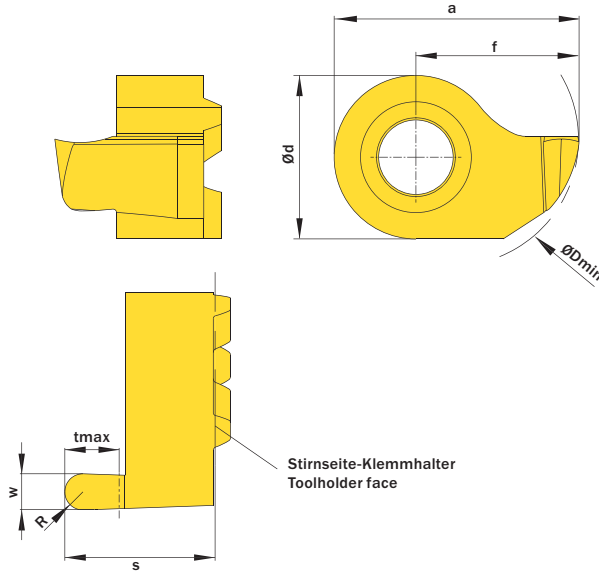

Stirnseite-Klemmhalter
Toolholder face

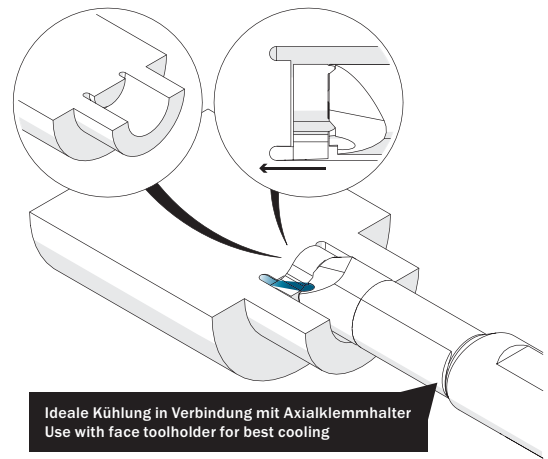

Abbildung zeigt / Drawing shows: D14.1420.10 AR

ØDmin (Min. Bohrung) ØDmin (min. bore)	w ^{+0,03}	R	Artikelnummer Part number	Webcode www.simtek.com/webcode	Unsere erste Wahl Our first choice	a	Ød	f	S	tmax	Connectcode www.simtek.com/code
mm	mm	mm			P K M N S	mm	mm	mm	mm	mm	
▼ tmax = 1,5 mm											
14,0	1,0	0,5	D14.1410.05 AR/L	R AEG0 L ACGA	X800 X400	13,5	9,0	9,0	8,3	1,5	R D14.A.R L D14.A.L
14,0	1,168	0,58	D14.1412.058 AV R	A4VQ	X800 X400	13,5	9,0	9,0	10,3	1,5	D14.A.R new inch
▼ tmax = 2,5 mm											
14,0	1,5	0,75	D14.1415.07 AR/L	R A1GH L A1GG	X800 X400	13,5	9,0	9,0	8,3	2,5	R D14.A.R L D14.A.L
14,0	1,6	0,8	D14.1416.08 AR/L	R ABNN L AFEQ	X800 X400	13,5	9,0	9,0	8,3	2,5	R D14.A.R L D14.A.L
▼ tmax = 3,0 mm											
14,0	2,0	1,0	D14.1420.10 AR/L	R APW0 L AHNX	X800 X400	13,5	9,0	9,0	8,3	3,0	R D14.A.R L D14.A.L
14,0	2,5	1,25	D14.1425.12 AR/L	R ANJW L ADX1	X800 X400	13,5	9,0	9,0	8,3	3,0	R D14.A.R L D14.A.L
14,0	3,0	1,5	D14.1430.15 AR/L	R AP37 L ABES	X800 X400	13,5	9,0	9,0	8,3	3,0	R D14.A.R L D14.A.L
▼ tmax = 5,0 mm											
14,0	2,0	1,0	D14.1420.50 AV R/L	R AWE5 L AWE4	X800 X400	13,5	9,0	9,0	10,3	5,0	R D14.A.R L D14.A.L
14,0	2,5	1,25	D14.1425.50 AV R/L	R AWE7 L AWE6	X800 X400	13,5	9,0	9,0	10,3	5,0	R D14.A.R L D14.A.L
14,0	3,0	1,5	D14.1430.50 AV R/L	R AWE9 L AWE8	X800 X400	13,5	9,0	9,0	10,3	5,0	R D14.A.R L D14.A.L

Bestellbeispiel // Order example: **D14.1420.10 AR X800** (R = Rechte Ausführung // Right hand version, X800 = Schneidstoff // Grade)