

Gewindedrehen, Metrisches ISO Vollprofil

Herstellung des vollständigen Gewindeprofils mit erforderlicher Tiefe.

Threading, Metric ISO Full Profile

For a complete thread profile with correct depth.

Schnittwerte (Start) // Cutting parameters (start)
Anzahl Durchgänge // Number of passes 10 - 16
Empf. Zustellungsart // Recom. infeed method Modifizierte einseitige Flankenzustellung // Modified one-sided flank infeed (Seite/Page 447)
Vc Seite/Page 442

Passende Klemmhalter auf Seite // Suitable toolholders on page
174, 176, 178, 180, 181

SP

HM

R

Legende
Legend **238**

Scan
QR-Code
 Oder besuchen Sie // Or Visit
www.simtek.info/cp/882



Abbildung zeigt / Drawing shows: D11.0815.02 MR

HC	Steigung TP Pitch TP	Artikelnummer Part number	Webcode www.simtek.com/webcode	Empfohlene Schneidstoffe Recommended cutting grades	a	b	HA	HB	Ød	ØDmin (Min. Bohrung) ØDmin (min. bore)	f	S	Connectcode www.simtek.com/code
mm	mm			Tagesaktuelle Verfügbarkeit und Preise finden Sie auf www.simtek.com/webcode You can find current availability and prices on www.simtek.com/webcode									
				P K M N S H O	mm	mm	mm	mm	mm	mm	mm	mm	

◀ Fortgesetzte Tabelle // Continued Table Verwandte Werkzeuge finden Sie auch auf der vorhergehenden Seite!
Related items can be found on the previous page as well!

▼ ØDmin (Min. Bohrung) // ØDmin (min. bore) = 14,0 mm																			
0,271	0,5	D14.0205.02 MR/L	R AG11	L AAM6	X800	X400	GX79	X500	X400	13,5	5,4	0,325	0,054	9,0	14,0	9,0	4,8	D14	upd
0,541	1,0	D14.0510.02 MR/L	R AGVA	L AN3Z	X800	X400	GX79	X500	X400	13,5	5,4	0,65	0,108	9,0	14,0	9,0	4,7	D14	upd
0,812	1,5	D14.0815.02 MR/L	R AAPD	L AHEZ	X800	X400	GX79	X500	X400	13,5	5,4	0,974	0,162	9,0	14,0	9,0	4,3	D14	upd
1,083	2,0	D14.1020.02 MR/L	R ABSD	L AMJS	X800	X400	GX79	X500	X400	13,5	5,4	1,299	0,217	9,0	14,0	9,0	4,2	D14	upd
1,353	2,5	D14.1325.02 MR/L	R AFMØ	L APW6	X800	X400	GX79	X500	X400	13,5	5,4	1,624	0,271	9,0	14,0	9,0	3,65	D14	upd
▼ ØDmin (Min. Bohrung) // ØDmin (min. bore) = 16,0 mm																			
0,541	1,0	D16.0510.02 MR/L	R ACØ7	L ACXP	X800	X400	GX79	X500	X400	15,7	5,5	0,65	0,108	11,0	16,0	10,2	4,8	D16	upd
0,812	1,5	D16.0815.02 MR/L	R ADSQ	L AGTH	X800	X400	GX79	X500	X400	15,7	5,5	0,974	0,162	11,0	16,0	10,2	4,3	D16	upd
1,083	2,0	D16.1020.02 MR/L	R AHC8	L ANXE	X800	X400	GX79	X500	X400	15,7	5,5	1,299	0,217	11,0	16,0	10,2	4,05	D16	upd
1,353	2,5	D16.1325.02 MR/L	R AMW1	L AG5U	X800	X400	GX79	X500	X400	15,7	5,5	1,624	0,271	11,0	16,0	10,2	4,2	D16	upd
1,624	3,0	D16.1630.02 MR/L	R AKHY	L AN34	X800	X400	GX79	X500	X400	15,7	5,5	1,949	0,325	11,0	16,0	10,2	4,0	D16	upd
1,894	3,5	D16.1835.02 MR/L	R AANW	L AG41	X800	X400	GX79	X500	X400	15,7	5,5	2,273	0,379	11,0	16,0	10,2	3,9	D16	upd
2,165	4,0	D16.2140.02 MR/L	R AD32	L AEED	X800	X400	GX79	X500	X400	15,7	5,5	2,598	0,433	11,0	16,0	10,2	3,6	D16	upd

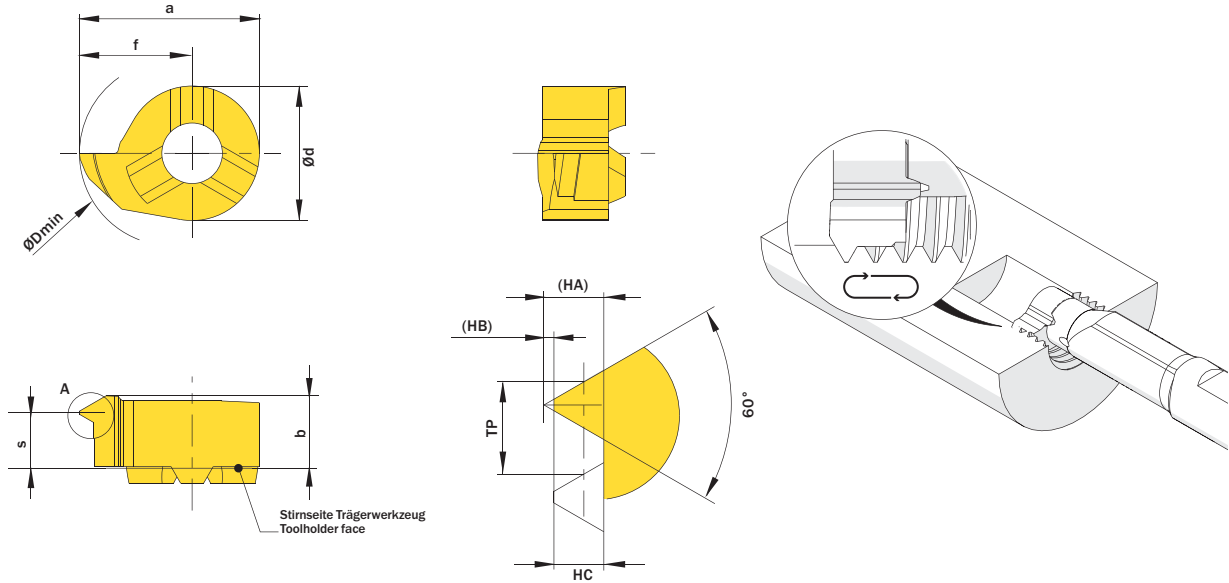
■ Bestellbeispiel // Order example: **D14.0815.02 MR X800** (R = Rechte Ausführung // Right hand version, X800 = Schneidstoff // Grade)