

# Nutenstechen

Für allgemeines Nutenstechen und für Sicherungsringnuten.  
Geeignet ab Bohrungsdurchmesser 18,0 mm.

# Grooving

For general grooving as well as for circlip ring grooving.  
For use in bores as of minimum bore diameter 18,0 mm.

Schnittwerte (Start) // Cutting parameters (start)	
f <b>0,02 mm/U</b>	Vc <b>Seite/Page 429</b>

Passende Klemmhalter auf Seite // Suitable toolholders on page  
**160, 164**

Vergleichbare Werkzeuge auf Seite // Similar tools on page  
**175**

SP

HM

R

Legende  
Legend **213**

Scan  
QR-Code Oder besuchen Sie // Or Visit  
[www.simtek.info/cp/843](http://www.simtek.info/cp/843)

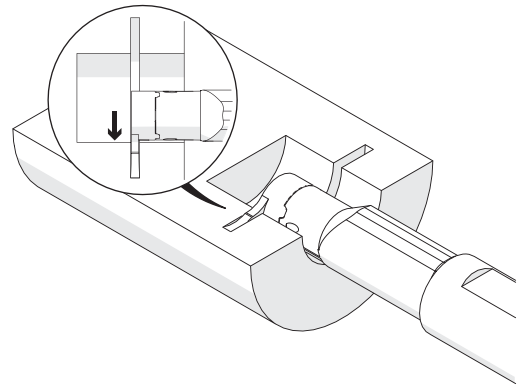
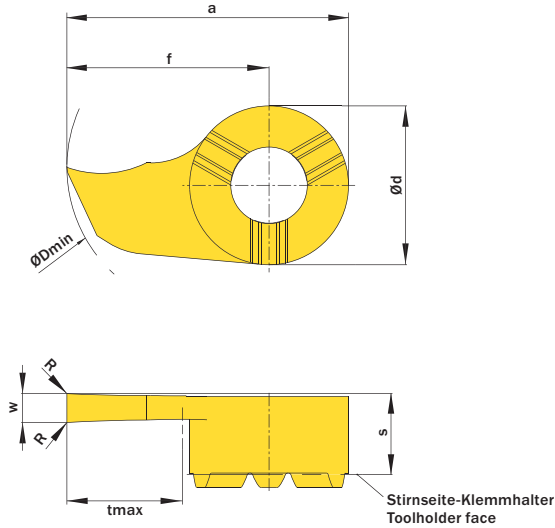

w <sup>+0,03</sup>	Nutnenbreite Nominal width of groove	ØDmin (Min. Bohrung) ØDmin (min. bore)	Artikelnummer Part number	Webcode www.simtek.com/webcode	Unsere erste Wahl Our first choice	a	Ød	f	R	S	tmax	Connectcode www.simtek.com/code
mm	mm	mm			P K M N S	mm	mm	mm	mm	mm	mm	

◀ Fortgesetzte Tabelle  
Continued Table

Verwandte Werkzeuge finden Sie auch auf der vorhergehenden Seite!  
Related items can be found on the previous page as well!

1,5	-	18,0	<b>D18.0150.00.18 GR/L</b>	R AKZ7 L AM2H	X800 X400	17,5	11,0	12,0	-	5,6	6,0	D18
2,0	-	18,0	<b>D18.0200.00.18 GR/L</b>	R AJ4W L AJFJ	X800 X400	17,5	11,0	12,0	-	5,6	6,0	D18
2,388	-	18,0	<b>D18.0238.00.18 GR/L</b>	R A1DG L A1DJ	X800 X400	17,5	11,0	12,0	-	5,6	6,0	D18
2,5	-	18,0	<b>D18.0250.00.18 GR/L</b>	R ADDT L AEK0	X800 X400	17,5	11,0	12,0	-	5,6	6,0	D18
3,0	-	18,0	<b>D18.0300.00.18 GR/L</b>	R AM20 L ANN X	X800 X400	17,5	11,0	12,0	-	5,6	6,0	D18
3,175	-	18,0	<b>D18.0318.00.18 GR/L</b>	R AVWC L AVWD	X800 X400	17,5	11,0	12,0	-	5,6	6,0	D18
3,5	-	18,0	<b>D18.0350.00.18 GR/L</b>	R AGY9 L ACQ7	X800 X400	17,5	11,0	12,0	-	5,6	6,0	D18
4,0	-	18,0	<b>D18.0400.00.18 GR/L</b>	R AC7M L AAVV	X800 X400	17,5	11,0	12,0	-	5,6	6,0	D18

Verwandte Werkzeuge finden Sie auch auf der folgenden Seite!  
Related items can be found on the following page as well!

▶ Fortgesetzte Tabelle  
Continued Table

Bestellbeispiel // Order example: **D18.0300.00.18 GR X800** (R = Rechte Ausführung // Right hand version, X800 = Schneidstoff // Grade)



D18. w, 1/100 mm, 4 Stellen/Digits . R, 1/100 mm, 3 Stellen/Digits .18 Toleranz // Tolerance R/L  
Beispielartikelnummer // Example Part number: **D18.0156.015.18 XN R** oder/ or **D18.0156.015.18 XN L**