

Ausdrehen

Geeignet ab Bohrungsdurchmesser 3,7 mm.

Boring

For use in bores as of minimum bore diameter 3,7 mm.

Schnittwerte (Start) // Cutting parameters (start)

f	Vc
0,02 mm/U	Seite/Page 429

Passende Klemmhalter auf Seite // Suitable toolholders on page

26, 31, 32, 33, 34, 40, 41, 43, 50,
51, 53, 55, 56, 57, 60, 62, 63, 65,
66, 67, 68, 69

Vergleichbare Werkzeuge auf Seite // Similar tools on page

70



Legende
Legend 139



Oder besuchen Sie // Or Visit
www.simtek.info/cp/1055

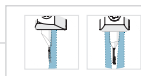
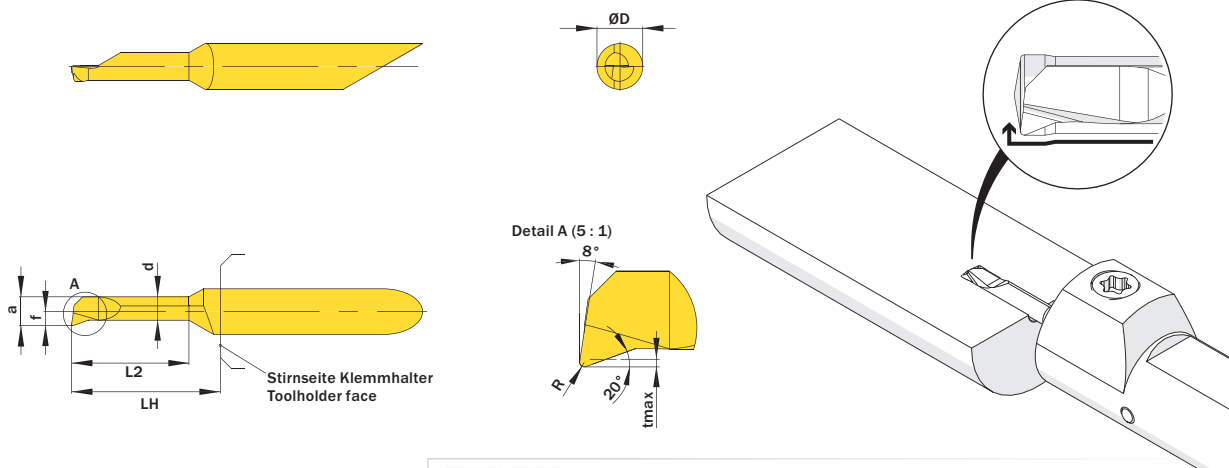

Mehr Informationen zur Kühlmittelzufuhr finden Sie auf Seite 22
Additional information about through coolant supply on page 22

ØD	L2	ØDmin (Min. Bohrung) ØDmin (min. bore)	R	Kühlmittelzufuhr Through coolant supply	Artikelnummer Part number	Webcode www.simtek.com/webcode	Unsere erste Wahl Our first choice	a	d	f	LH	tmax	Connectcode www.simtek.com/code
mm	mm	mm	mm				P K M N S	mm	mm	mm	mm	mm	

Fortgesetzte Tabelle Continued Table
Verwandte Werkzeuge finden Sie auch auf der vorhergehenden Seite!
Related Items can be found on the previous page as well!

4,0	10,2	3,7	0,15	●	A04.1817.10.37.15 YR/L	R AHD4 L AMYK	X800 X400	3,45	3,05	1,7	13,0	0,2	R A04.R L A04.L
4,0	10,2	3,7	0,15	+	A04.1C17.10.37.15 YR/L	R ANJF L ANZP	X800 X400	3,45	3,05	1,95	13,0	0,2	R A04C.R L A04C.L
4,0	15,2	3,7	0,15	●	A04.1817.15.37.15 YR/L	R AMQN L ABA7	X800 X400	3,45	3,05	1,7	18,0	0,2	R A04.R L A04.L
4,0	15,2	3,7	0,15	+	A04.1C17.15.37.15 YR/L	R AHBD L APYD	X800 X400	3,45	3,05	1,95	18,0	0,2	R A04C.R L A04C.L
4,0	20,3	3,7	0,05	●	A04.1817.20.37.05 YR/L	R AQ1U L AQ1V	X800 X400	3,45	3,05	1,7	23,0	0,2	R A04.R L A04.L
4,0	20,3	3,7	0,05	+	A04.1C17.20.37.05 YR/L	R AW9U L AXAN	X800 X400	3,45	3,05	1,95	23,0	0,2	R A04C.R L A04C.L
4,0	20,3	3,7	0,15	●	A04.1817.20.37.15 YR/L	R AKNZ L AH9Y	X800 X400	3,45	3,05	1,7	23,0	0,2	R A04.R L A04.L
4,0	20,3	3,7	0,15	+	A04.1C17.20.37.15 YR/L	R AB5S L AFAA	X800 X400	3,45	3,05	1,95	23,0	0,2	R A04C.R L A04C.L
4,0	25,4	3,7	0,1	●	A04.1817.25.37.10 YR/L	R AA9M L ADKH	X800 X400	3,45	3,05	1,7	28,0	0,2	R A04.R L A04.L
4,0	25,4	3,7	0,1	+	A04.1C17.25.37.10 YR/L	R ANNS L AEFW	X800 X400	3,45	3,05	1,95	28,0	0,2	R A04C.R L A04C.L
4,0	30,5	3,7	0,1	+	A04.1C17.30.37.10 YR	R A2AE	X800 X400	3,45	3,05	1,95	33,0	0,2	A04C.R

Verwandte Werkzeuge finden Sie auch auf der folgenden Seite!
Related Items can be found on the following page as well!

Fortgesetzte Tabelle Continued Table

Bestellbeispiel // Order example: A04.1817.15.37.15 YR X800 (R = Rechte Ausführung // Right hand version, X800 = Schneidstoff // Grade)