

# Abstechen

Verfügbar in verschiedenen Winkeln,  
 Breiten und mit/ohne geschliffener Spanformrinne.

# Parting Off

Available in different angles,  
 widths and with/without ground chip form channel.

Schnittwerte (Start) // Cutting parameters (start)

f	Vc
0,08 mm/U	Seite/Page 429

Passende Klemmhalter auf Seite // Suitable toolholders on page  
**361, 362, 363, 364, 365, 366, 367, 368**

**SP**  
**HM**  
**R**

Legende  
Legend **389**

Scan  
QR-Code

Oder besuchen Sie // Or Visit  
[www.simtek.info/cp/513](http://www.simtek.info/cp/513)

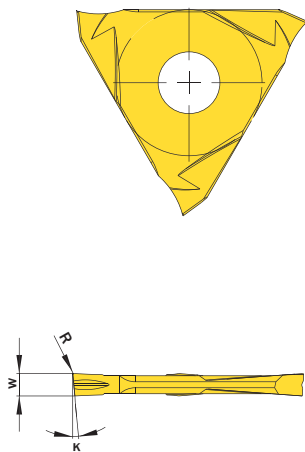

Abbildungen ähnlich // Similar illustrations



E12...00 P R  
E12...PS R



E12...11 P R  
E12...PT R

! Bearbeitbare Materialien. Siehe unten.  
 ! Machineable materials. See below.



Abbildung zeigt / Drawing shows: E12.1520.11 P R

K	w <sup>-0,05</sup> mm	Artikelnummer Part number	Webcode www.simtek.com/webcode	Unsere erste Wahl Our first choice	Mit Spanformrinne With chip form channel	R mm	Connectcode www.simtek.com/code
<b>▼ w = 1,0 mm</b>							
12°	1,0	<b>E12.1210.00 P R/L</b>	R AFQD L AB4M X800 X400	Nein / No	0,1	E12.A1 E12.A2	
12°	1,0	<b>E12.1210.11 P R/L</b>	R ANDX L AMEB X800 X400	Ja / Yes	0,1	E12.A1 E12.A2	
<b>▼ w = 1,3 mm</b>							
6°-7°	1,3	<b>E12.0613.11 P R/L</b>	R ABPV L AEZZ X800 X400	Ja / Yes	0,1	E12.A1 E12.A2	
<b>▼ w = 1,6 mm</b>							
6°-7°	1,6	<b>E12.0516.00 P R/L</b>	R ACV8 L AF73 X800 X400	Nein / No	0,1	E12.A1 E12.A2	
6°-7°	1,6	<b>E12.0516.11 P R/L</b>	R AMGM L ACKA X800 X400	Ja / Yes	0,1	E12.A1 E12.A2	
6°-7°	1,6	<b>E12.0516.68 PS R/L</b>	R AWEK L AWEN X800 X400	Nein / No	0,1	E68.A1	
6°-7°	1,6	<b>E12.0516.68 PT R/L</b>	R AWEQ L AWEP X800 X400	Ja / Yes	0,1	E68.A1	
<b>▼ w = 2,0 mm</b>							
5°-6°	2,0	<b>E12.0520.00 P R/L</b>	R AC2J L ACEX X800 X400	Nein / No	0,1	E12.A1 E12.A2	
5°-6°	2,0	<b>E12.0520.11 P R/L</b>	R ANDM L AJEN X800 X400	Ja / Yes	0,1	E12.A1 E12.A2	
15°	2,0	<b>E12.1520.11 P R/L</b>	R AFED L APJT X800 X400	Ja / Yes	0,1	E12.A1 E12.A2	
<b>▼ w = 2,1 mm</b>							
5°-6°	2,1	<b>E12.0521.11 P R/L</b>	R AN1B L AHHT X800 X400	Ja / Yes	0,1	E12.A2 E12.B2	

! Bestellbeispiel // Order example: **E12.1210.11 P R X800** (R = Rechte Ausführung // Right hand version, X800 = Schneidstoff // Grade)

! E12...00 P R / E12...PS R: Für die Bearbeitung eines breiten Metarialspektrums // For a wide variety of workpiecematerials.

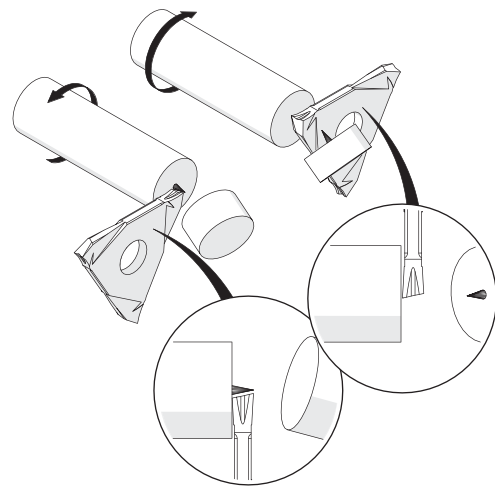
! E12...11 P R / E12...PT R: Für die Bearbeitung eines breiten Metarialspektrums sowie besonders für langspanendes Material und hohe Stechtiefen.  
 For a wide variety of workpiecematerials as well as especially for long-chipping materials and high cutting depths.