

Gewindedrehen, Metr. ISO, Außen, Vollprofil

Herstellung des vollständigen Gewindeprofils mit notwendiger Tiefe sowie Kopf- und Fußradien.

Threading, Metr. ISO, external, full profile

For a complete thread profile with correct depth, top radius and bottom radius.

Schnittwerte (Start) // Cutting parameters (start)

Anzahl Durchgänge // Number of passes
8 - 12

Empf. Zustellungsart // Recom. infeed method
Flankenzustellung // Flank infeed (Seite/Page 433)

Vc Seite/Page **429**

Passende Klemmhalter auf Seite // Suitable toolholders on page
323, 324, 325, 326, 327, 328



SP HM R Legende 354
 Scan QR-Code Oder besuchen Sie // Or Visit
www.simtek.info/cp/313

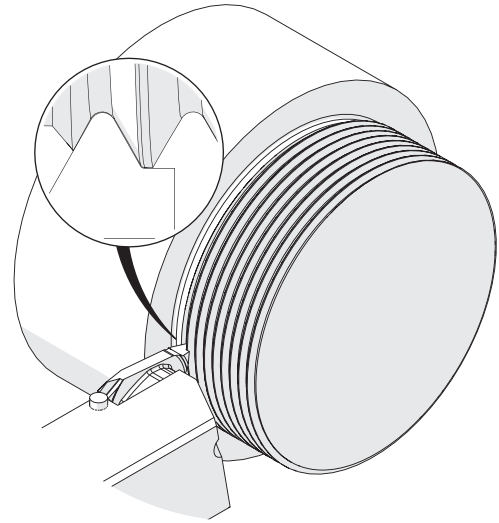
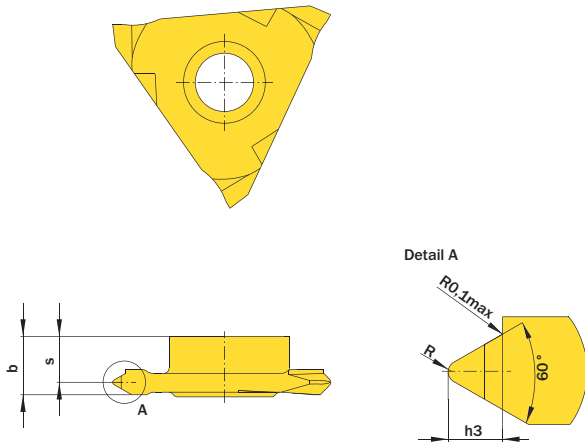

Abbildung zeigt / Drawing shows: TE3.MT20.02 EM R

Steigung (von) Pitch (as of)	Artikelnummer Part number	Webcode www.simtek.com/webcode	Unsere erste Wahl Our first choice		b	h3	R	S	Connectcode www.simtek.com/code	
			P	K					M	N
0,5	TE3.MT05.02 EM R/L	R AV91 L AV92	X800	X400	5,6	0,31	0,07	4,8	R	TE3.R.5.3 L TE3.L.5.3
0,75	TE3.MT07.02 EM R/L	R AQVT L ATWK	X800	X400	5,6	0,46	0,11	4,8	R	TE3.R.5.3 L TE3.L.5.3
0,8	TE3.MT08.02 EM R/L	R ASFS L ATWM	X800	X400	5,6	0,49	0,12	4,7	R	TE3.R.5.3 L TE3.L.5.3
1,0	TE3.MT10.02 EM R/L	R AFHK L ANBA	X800	X400	5,6	0,61	0,14	4,6	R	TE3.R.5.3 L TE3.L.5.3
1,25	TE3.MT12.02 EM R/L	R ABFQ L AEP4	X800	X400	5,6	0,77	0,18	4,5	R	TE3.R.5.3 L TE3.L.5.3
1,5	TE3.MT15.02 EM R/L	R AKFX L ABVJ	X800	X400	5,6	0,92	0,22	4,4	R	TE3.R.5.3 L TE3.L.5.3
1,75	TE3.MT17.02 EM R/L	R AHWM L AJFB	X800	X400	5,6	1,07	0,25	4,1	R	TE3.R.5.3 L TE3.L.5.3
2,0	TE3.MT20.02 EM R/L	R ABX6 L AHXC	X800	X400	5,6	1,23	0,29	4,1	R	TE3.R.5.3 L TE3.L.5.3
2,5	TE3.MT25.02 EM R/L	R ADA1 L AAXP	X800	X400	5,6	1,53	0,36	3,9	R	TE3.R.5.3 L TE3.L.5.3
3,0	TE3.MT30.02 EM R/L	R AMUN L ANFC	X800	X400	5,6	1,84	0,43	3,8	R	TE3.R.5.3 L TE3.L.5.3
3,5	TE3.MT35.02 EM R/L	R AP36 L AM6F	X800	X400	5,6	2,15	0,51	3,5	R	TE3.R.5.3 L TE3.L.5.3
4,0	TE3.MT40.02 EM R/L	R AAAW L AAFC	X800	X400	5,6	2,45	0,58	3,6	R	TE3.R.5.3 L TE3.L.5.3
5,0	TE3.MT50.02 EM R/L	R AB6F L AMYX	X800	X400	5,95	3,07	0,72	3,55	R	TE3.R.5.3 L TE3.L.5.3
6,0	TE3.MT60.02 EM R/L	R AGXM L AMSW	X800	X400	6,6	3,68	0,87	3,5	R	TE3.R.5.3 L TE3.L.5.3

Bestellbeispiel // Order example: **TE3.MT15.02 EM R X800** (R = Rechte Ausführung // Right hand version, X800 = Schneidstoff // Grade)

simturn AX
simturn DX
simturn PX
simturn H2
simturn K2
simturn C4
simturn GX
simturn E3
simturn E12
simturn FX
simturn Decolletage
simturn OA
Index