

Allgemeines Nutfräsen

Nutfräsen gerader Nutformen.
Geeignet ab Bohrungsdurchmesser 18,0 mm.

General Groove Milling

General groove milling.
For use in bores as of minimum bore diameter 18,0 mm.

Schnittwerte (Start) // Cutting parameters (start)		
fzm 0,03 mm	hmax 0,04 mm	Vc Seite/Page 638
Passende Klemmhalter auf Seite // Suitable toolholders on page		
529, 530, 531, 532, 533		
Vergleichbare Werkzeuge auf Seite // Similar tools on page		
461		
Bitte Hinweise im Anhang beachten // Please read add. notes		
ALL (Seite/Page 645), H01 (Seite/Page 646)		

SP Legende
HM Legend

650

Scan QR-Code Oder besuchen Sie // Or Visit
www.simtek.info/cp/361

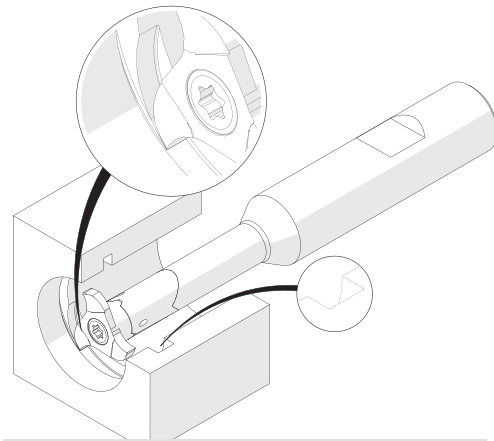
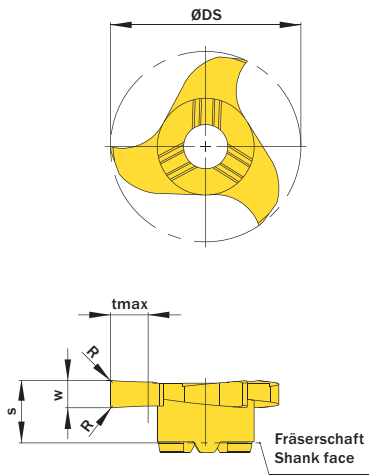

Illustration zeigt beispielhafte Anwendungsmöglichkeit mit ähnlichem Werkzeug.
Image shows exemplary application possibility with similar tool.

Abbildung zeigt / Drawing shows: U18.0250.02 G

w ^{+0,02} mm	Nutnenbreite Nominal width of groove mm	R mm	ØDmin (Min. Bohrung) ØDmin (min. bore) mm	Artikelnummer Part number	Webcode www.simtek.com/webcode	Unsere erste Wahl Our first choice		tmax mm	s mm	ØDS mm	Anzahl Schneiden Number of cutting edges	Connectcode www.simtek.com/code	Inch
						P M K N S							
1,168	-	-	18,0	U18.0117.00 G	AAU0	X800	GT42	3,5	5,8	17,7	3	UD09.0	Inch
1,422	-	-	18,0	U18.0142.00 G	ANB1	X800	GT42	3,5	5,8	17,7	3	UD09.0	Inch
1,5	-	0,2	18,0	U18.0150.02 G	AMW2	X800	GT42	3,5	5,8	17,7	3	UD09.0	Inch
1,549	-	0,2	18,0	U18.0157.02 G	AJ80	X800	GT42	3,5	5,8	17,7	3	UD09.0	Inch
2,0	-	0,2	18,0	U18.0200.02 G	AJXK	X800	GT42	3,5	5,8	17,7	3	UD09.0	Inch
2,388	-	0,2	18,0	U18.0239.02 G	AG6E	X800	GT42	3,5	5,8	17,7	3	UD09.0	Inch
2,5	-	0,2	18,0	U18.0250.02 G	ABXH	X800	GT42	3,5	5,8	17,7	3	UD09.0	Inch
3,0	-	0,2	18,0	U18.0300.02 G	ADJZ	X800	GT42	3,5	5,8	17,7	3	UD09.0	Inch
3,175	-	0,2	18,0	U18.0318.02 G	AJZU	X800	GT42	3,5	5,8	17,7	3	UD09.0	Inch
4,0	-	0,2	18,0	U18.0400.02 G	AJUU	X800	GT42	3,5	5,8	17,7	3	UD09.0	Inch

Bestellbeispiel // Order example: **U18.0300.02 G X800** (X800 = Schneidstoff // Grade)



U18. w, 1/100 mm, 4 Stellen/Digits . R, 1/100 mm, 3 Stellen/Digits Toleranz // Tolerance

Beispielartikelnummer // Example Part number: **U18.0179.030 XG**

simmill AX
simmill PMX
simmill PX
simmill SX
simmill UX
simmill VX
simmill H2
simmill K2
simmill MX
simmill OS
Index