

# Ausdrehen

Geeignet ab Bohrungsdurchmesser 7,0 mm.

# Boring

For use in bores as of minimum bore diameter 7,0 mm.

Schnittwerte (Start) // Cutting parameters (start)

f	Vc
0,02 mm/U	Seite/Page 429

Passende Klemmhalter auf Seite // Suitable toolholders on page

153, 154, 155, 156, 157, 158, 159, 161, 162, 163, 164



**SP** **HM** **R** **Legende Legend 213**  
Scan QR-Code Oder besuchen Sie // Or Visit [www.simtek.info/cp/813](http://www.simtek.info/cp/813)

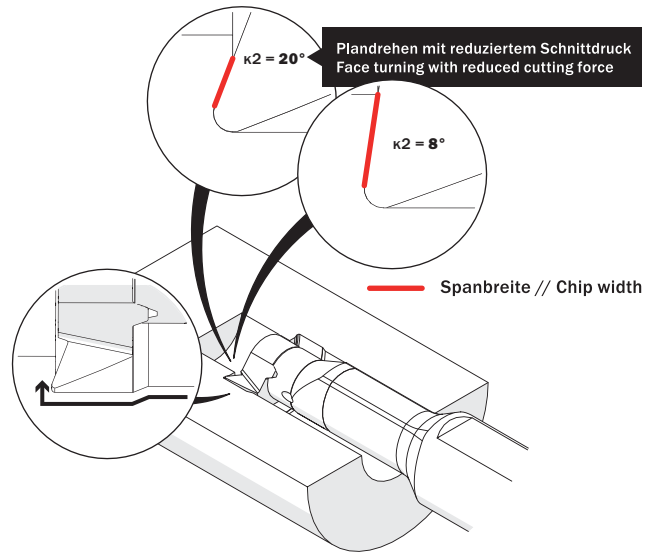
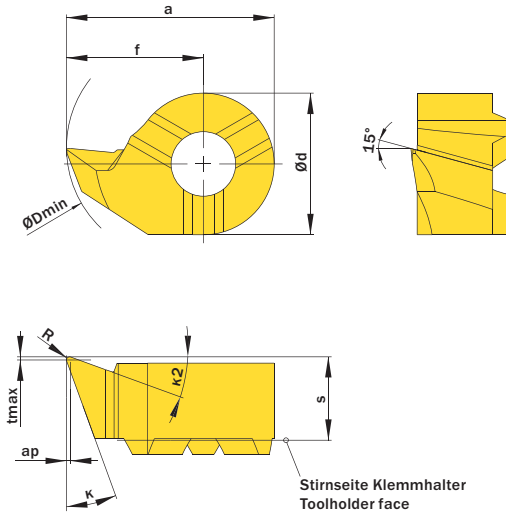

Abbildung zeigt / Drawing shows: D14.2087.02 YR

ØDmin (Min. Bohrung) // ØDmin (min. bore)	k	κ2	f	R	Artikelnummer Part number	Webcode www.simtek.com/webcode	Unsere erste Wahl Our first choice				a	Ød	S	ap	tmax	Connectcode www.simtek.com/code	upd
							P	K	M	S							
▼ ØDmin (Min. Bohrung) // ØDmin (min. bore) = 7,0 mm																	
7,0	18°	8°	4,15	0,1	<b>D07.1841.01 YR/L</b>	R ANWE	L AXA8	X800	X400	6,55	4,8	3,7	0,13	0,2	D07	upd	
7,0	18°	8°	4,15	0,2	<b>D07.1841.02 YR/L</b>	R AJZ7	L AXA9	X800	X400	6,55	4,8	3,7	0,25	0,2	D07	upd	
▼ ØDmin (Min. Bohrung) // ØDmin (min. bore) = 7,8 mm																	
7,8	18°	8°	4,65	0,05	<b>D08.1846.005 YR/L</b>	R AS56	L AS55	X800	X400	7,65	6,0	3,5	0,07	0,2	D08		
7,8	18°	8°	4,65	0,2	<b>D08.1846.02 YR/L</b>	R AMM3	L AC6Z	X800	X400	7,65	6,0	3,5	0,25	0,2	D08		
7,8	20°	20°	4,65	0,2	<b>D08.2046.02 YR/L</b>	R AG7V	L AFEB	X800	X400	7,65	6,0	3,5	0,25	0,2	D08		
▼ ØDmin (Min. Bohrung) // ØDmin (min. bore) = 9,0 mm																	
9,0	18°	8°	5,5	0,2	<b>D09.1855.02.09 YR/L</b>	R AWGU	L AWH7	X800	X400	8,6	6,2	3,6	0,25	0,2	D09		
9,0	20°	20°	5,5	0,2	<b>D09.2055.02.09 YR/L</b>	R AWGV	L AWH8	X800	X400	8,6	6,2	3,6	0,25	0,2	D09		
▼ ØDmin (Min. Bohrung) // ØDmin (min. bore) = 9,8 mm																	
9,8	18°	8°	5,5	0,2	<b>D11.1855.02 YR/L</b>	R AC65	L AHXM	X800	X400	9,5	8,0	4,2	0,25	0,2	D11		
▼ ØDmin (Min. Bohrung) // ØDmin (min. bore) = 10,0 mm																	
10,0	18°	8°	5,6	0,2	<b>D10.1856.02.10 YR/L</b>	R AN4S	L AGF7	X800	X400	9,1	7,0	3,9	0,25	0,2	D10		
10,0	20°	20°	5,6	0,2	<b>D10.2056.02.10 YR/L</b>	R AD7E	L AB48	X800	X400	9,1	7,0	3,9	0,25	0,2	D10		
▼ ØDmin (Min. Bohrung) // ØDmin (min. bore) = 11,0 mm																	
11,0	18°	8°	6,6	0,2	<b>D10.1866.02.11 YR/L</b>	R AFCG	L AW40	X800	X400	9,1	7,0	3,9	0,25	0,2	D10		
11,0	18°	8°	6,7	0,2	<b>D11.1867.02 YR/L</b>	R ABXG	L AF60	X800	X400	10,7	8,0	4,2	0,25	0,2	D11		
11,0	20°	20°	6,7	0,2	<b>D11.2067.02 YR/L</b>	R APSF	L AKP5	X800	X400	10,7	8,0	4,2	0,25	0,2	D11		
▼ ØDmin (Min. Bohrung) // ØDmin (min. bore) = 13,8 mm																	
13,8	18°	8°	8,7	0,2	<b>D14.1887.02 YR/L</b>	R AN1M	L AGJY	X800	X400	13,2	9,0	5,3	0,25	0,2	D14		
13,8	18°	8°	8,7	0,4	<b>D14.1887.04 YR/L</b>	R AZF7	L AZF8	X800	X400	13,2	9,0	5,3	0,5	0,2	D14	upd	
13,8	20°	20°	8,7	0,2	<b>D14.2087.02 YR/L</b>	R AG2U	L AGQC	X800	X400	13,2	9,0	5,3	0,25	0,2	D14		
▼ ØDmin (Min. Bohrung) // ØDmin (min. bore) = 15,5 mm																	
15,5	18°	8°	9,7	0,2	<b>D16.1897.02 YR/L</b>	R AHEA	L ADN	X800	X400	15,2	11,0	5,4	0,25	0,2	D16		

Bestellbeispiel // Order example: **D08.1846.02 YR X800** (R = Rechte Ausführung // Right hand version, X800 = Schneidstoff // Grade)