

# Allgemeines Nutfräsen

Nutfräsen gerader Nutformen.  
 Geeignet ab Bohrungsdurchmesser 18,0 mm.

# General Groove Milling

General groove milling.  
 For use in bores as of minimum bore diameter 18,0 mm.

Schnittwerte (Start) // Cutting parameters (start)		
fzm <b>0,03 mm</b>	hmax <b>0,04 mm</b>	Vc <b>Seite/Page 638</b>
Passende Klemmhalter auf Seite // Suitable toolholders on page		
<b>529, 530, 531, 532, 533</b>		
Vergleichbare Werkzeuge auf Seite // Similar tools on page		
<b>461</b>		
Bitte Hinweise im Anhang beachten // Please read add. notes		
<b>ALL (Seite/Page 645), H01 (Seite/Page 646)</b>		

**SP** Legende  
**HM** Legend

**650**

Scan QR-Code Oder besuchen Sie // Or Visit  
[www.simtek.info/cp/361](http://www.simtek.info/cp/361)

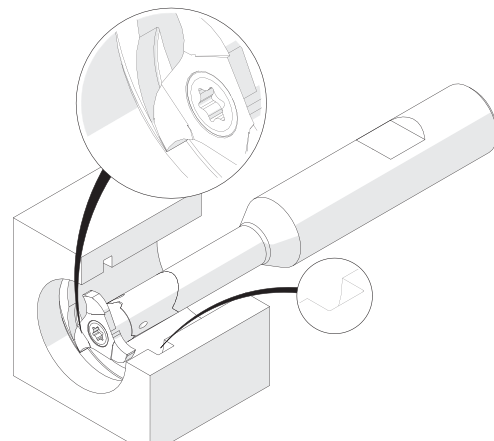
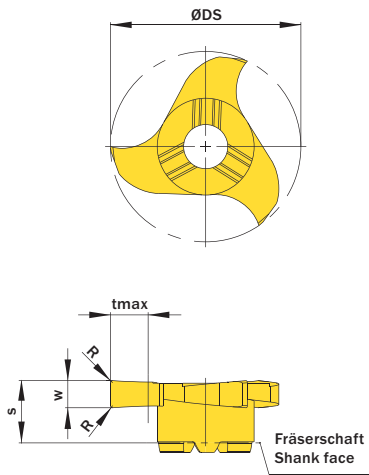

Illustration zeigt beispielhafte Anwendungsmöglichkeit mit ähnlichem Werkzeug.  
 Image shows exemplary application possibility with similar tool.

Abbildung zeigt / Drawing shows: U18.0250.02 G

w <sup>+0,02</sup> mm	Nutnennbreite Nominal width of groove mm	R mm	ØDmin (Min. Bohrung) ØDmin (min. bore) mm	Artikelnummer Part number	Webcode www.simtek.com/webcode	Unsere erste Wahl Our first choice		tmax mm	S mm	ØDS mm	Anzahl Schneiden Number of cutting edges	Connectcode www.simtek.com/code	inch
						P M K N S	G T						
1,168	-	-	18,0	<b>U18.0117.00 G</b>	AAU0	X800	G T42	3,5	5,8	17,7	3	UD09.0	inch
1,422	-	-	18,0	<b>U18.0142.00 G</b>	ANB1	X800	G T42	3,5	5,8	17,7	3	UD09.0	inch
<b>1,5</b>	-	<b>0,2</b>	<b>18,0</b>	<b>U18.0150.02 G</b>	AMW2	X800	G T42	<b>3,5</b>	<b>5,8</b>	<b>17,7</b>	<b>3</b>	<b>UD09.0</b>	
1,549	-	0,2	18,0	<b>U18.0157.02 G</b>	AJ80	X800	G T42	3,5	5,8	17,7	3	UD09.0	inch
2,0	-	0,2	18,0	<b>U18.0200.02 G</b>	AJXK	X800	G T42	3,5	5,8	17,7	3	UD09.0	
2,388	-	0,2	18,0	<b>U18.0239.02 G</b>	AG6E	X800	G T42	3,5	5,8	17,7	3	UD09.0	inch
2,5	-	0,2	18,0	<b>U18.0250.02 G</b>	ABXH	X800	G T42	3,5	5,8	17,7	3	UD09.0	
3,0	-	0,2	18,0	<b>U18.0300.02 G</b>	ADJZ	X800	G T42	3,5	5,8	17,7	3	UD09.0	
3,175	-	0,2	18,0	<b>U18.0318.02 G</b>	AJZU	X800	G T42	3,5	5,8	17,7	3	UD09.0	inch
4,0	-	0,2	18,0	<b>U18.0400.02 G</b>	AJUU	X800	G T42	3,5	5,8	17,7	3	UD09.0	

Bestellbeispiel // Order example: **U18.0300.02 G X800** (X800 = Schneidstoff // Grade)



U18. w, 1/100 mm, 4 Stellen/Digits . R, 1/100 mm, 3 Stellen/Digits Toleranz // Tolerance

Beispielartikelnummer // Example Part number: **U18.0179.030 XG**

simmill AX

simmill PMX

simmill PX

simmill SX

simmill UX

simmill VX

simmill H2

simmill K2

simmill MX

simmill OS

Index