

Einstecken und Profildrehen, Vollradius

Vollradiusnuten, CNC-Konturdrehen.

Grooving and Profiling, Full Radius

Full radius, CNC profiling.

Schnittwerte (Start) // Cutting parameters (start)

f (außen//ext.) 0,05 mm/U	f (innen//int.) 0,04 mm/U	Vc Seite/Page 429
-------------------------------------	-------------------------------------	-----------------------------

Passende Klemmhalter auf Seite // Suitable toolholders on page

295, 296, 297, 298, 299, 300, 301, 302, 303



SP Legende
HM Legend

315



Scan
 QR-Code

Oder besuchen Sie // Or Visit
www.simtek.info/cp/523

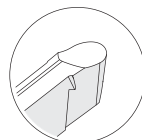
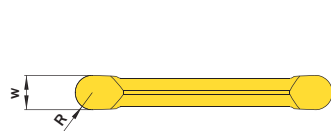
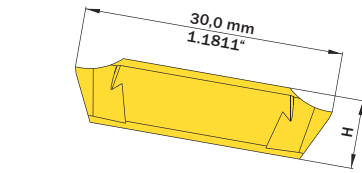

G29.00 ...S



G29.CB...S

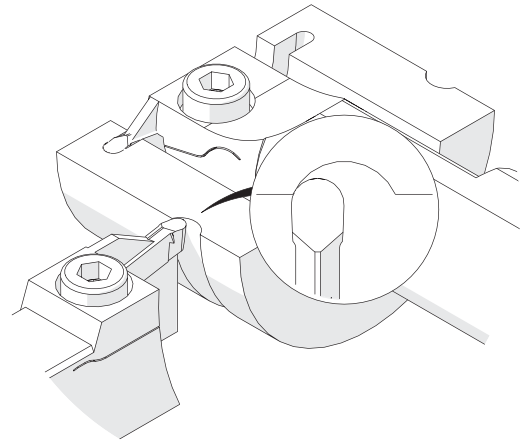

Abbildung zeigt / Drawing shows: G29.0040.20 S

$w^{+0,05}$ mm	R mm	Artikelnummer Part number	Webcode www.simtek.com/webcode	Unsere erste Wahl Our first choice P K M N S	H mm	Connectcode www.simtek.com/ccode
▼ w = 2,0 mm						
2,0	1,0	G29.0020.10 S	ADWN	X800 X400	7,9	G29.02
▼ w = 3,0 mm						
3,0	1,5	G29.0030.15 S	ANAZ	X800 X400	7,9	G29.03
▼ w = 4,0 mm						
4,0	2,0	G29.0040.20 S	AK7N	X800 X400	7,9	G29.03 G29.04
4,0	2,0	G29.CB40.20 S	A2WM	X800 X400	7,9	G29.03 G29.04 <small>upd</small>
▼ w = 5,0 mm						
5,0	2,5	G29.0050.25 S	ANTE	X800 X400	7,9	G29.04
▼ w = 6,0 mm						
6,0	3,0	G29.0060.30 S	AME9	X800 X400	7,5	G29.06
6,0	3,0	G29.CB60.30 S	A172	X800 X400	7,5	G29.06

Bestellbeispiel // Order example: **G29.0030.15 S X800** (X800 = Schneidstoff // Grade)