

Axialstechen in Bohrungen

Volle Stechtiefe ab Bohrungsdurchmesser 20,0 mm.
Reduzierte Stechtiefe bereits ab Bohrungsdurchmesser 12,0 mm.

Face Grooving in Bores

Full cutting depth as of minimum bore diameter 20,0 mm.
Reduced cutting depth possible as of minimum bore diameter 12,0 mm.

Schnittwerte (Start) // Cutting parameters (start)

f	Vc
0,02 mm/U	Seite/Page 429

Passende Klemmhalter auf Seite // Suitable toolholders on page
30, 39, 48, 52, 54, 59, 68



SP
HM
R

Legende
Legend **139**

Scan
QR-Code

Oder besuchen Sie // Or Visit
www.simtek.info/cp/762

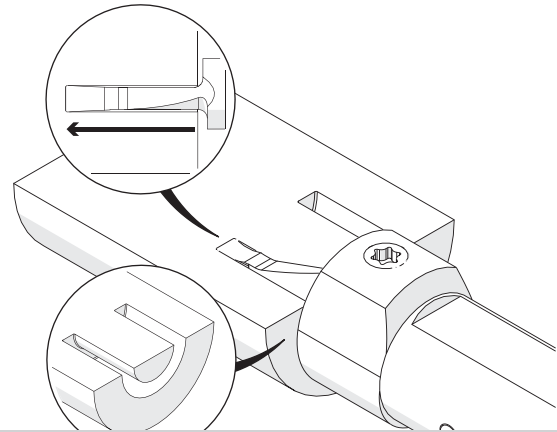
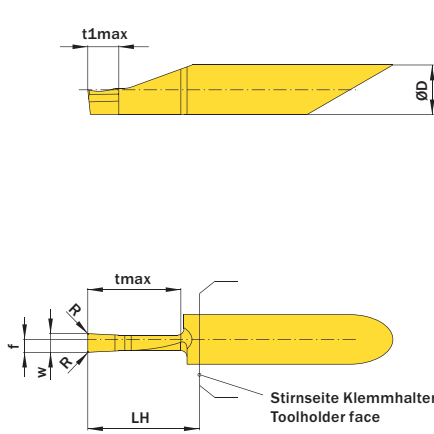

Stechtiefe „tmax“ gilt ab Bohrungsdurchmesser gem. Angabe in Spalte „Ab Bohrungsdurchmesser“
Stechtiefe „t1max“ gilt ab Bohrungsdurchmesser gem. Angabe in Spalte „D1min“
Cutting depth „tmax“ is possible as of bore diameter as stated in column „As of bore diameter“
Cutting depth „t1max“ is possible as of bore diameter as stated in column „D1min“

Abbildung zeigt / Drawing shows: A08.0300.15.00 AG R

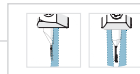

Mehr Informationen zur Kühlmittelzufuhr finden Sie auf Seite 22
Additional information about through coolant supply on page 22

ØD	w ^{+0,05}	tmax	Kühlmittelzufuhr Through coolant supply	Artikelnummer Part number	Webcode www.simtek.com/webcode	Unsere erste Wahl Our first choice	ØDmin (Min. Bohrung) ØDmin (min. bore)	t1max	D1min	f	LH	R	Connectcode www.simtek.com/code
mm	mm	mm				P K M N S	mm	mm	mm	mm	mm	mm	
▼ w = 3,0 mm													
10,0	3,0	20,0	+	A10.0300.20.00 AG R/L	R AAUC	L ABVX X800 X400	20,0	5,0	12,0	2,07	28,0	0,2	R A10.R L A10.L
10,0	3,0	25,0	+	A10.0300.25.00 AG R/L	R AENK	L AEYQ X800 X400	20,0	5,0	12,0	2,07	33,0	0,2	R A10.R L A10.L
10,0	3,0	30,0	+	A10.0300.30.00 AG R/L	R AP2X	L APZ8 X800 X400	20,0	5,0	12,0	2,07	38,0	0,2	R A10.R L A10.L
▼ w = 4,0 mm													
10,0	4,0	20,0	+	A10.0400.20.00 AG R/L	R AMDH	L AJPZ X800 X400	20,0	5,0	12,0	2,65	28,0	0,2	R A10.R L A10.L
10,0	4,0	25,0	+	A10.0400.25.00 AG R/L	R AMKB	L AME8 X800 X400	20,0	5,0	12,0	2,65	33,0	0,2	R A10.R L A10.L
10,0	4,0	30,0	+	A10.0400.30.00 AG R/L	R AKHQ	L AB12 X800 X400	20,0	5,0	12,0	2,65	38,0	0,2	R A10.R L A10.L
▼ w = 5,0 mm													
10,0	5,0	20,0	+	A10.0500.20.00 AG R/L	R AKXP	L AAXF X800 X400	20,0	5,0	12,0	3,1	28,0	0,2	R A10.R L A10.L
10,0	5,0	25,0	+	A10.0500.25.00 AG R/L	R AA6G	L AH2U X800 X400	20,0	5,0	12,0	3,1	33,0	0,2	R A10.R L A10.L
10,0	5,0	30,0	+	A10.0500.30.00 AG R/L	R AFJH	L AN46 X800 X400	20,0	5,0	12,0	3,1	38,0	0,2	R A10.R L A10.L

Bestellbeispiel // Order example: **A10.0300.20.00 AG R X800** (R = Rechte Ausführung // Right hand version, X800 = Schneidstoff // Grade)