

Stechen, schmale Runddrahtsprengringe

Runddrahtsprengringe, vgl. DIN 7993.

Grooving, Slim Round-Wire Snap-Ring

Round-wire snap-ring, comparing to DIN 7993.

Schnittwerte (Start) // Cutting parameters (start)

f	Vc
0,04 mm/U	Seite/Page 429

Passende Klemmhalter auf Seite // Suitable toolholders on page

361, 362, 363, 364, 365, 367, 368



SP Legende
HM Legend

389

Scan
 QR-Code

Oder besuchen Sie // Or Visit
www.simtek.info/cp/496

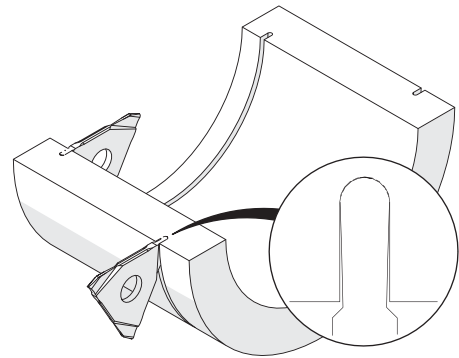
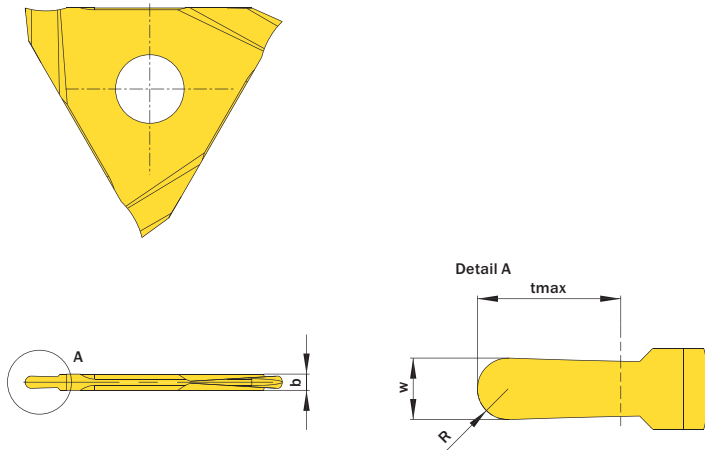

Abbildung zeigt / Drawing shows: E12.1305.00 V

$b \pm 0,02$	R	Artikelnummer Part number	Webcode www.simtek.com/webcode	Unsere erste Wahl Our first choice	tmax	$w \pm 0,03$	Connectcode www.simtek.com/ccode
mm	mm			P K M N S	mm	mm	
1,3	0,2	E12.1302.00 V	AMYV	X800 X400	0,6	0,4	E12.A1 E12.A2
1,3	0,25	E12.1302.05 V	A2WD	X800 X400	0,85	0,5	E12.A1 E12.A2
1,3	0,3	E12.1303.00 V	AC92	X800 X400	1,1	0,6	E12.A1 E12.A2
1,3	0,4	E12.1304.00 V	AA2Q	X800 X400	1,8	0,8	E12.A1 E12.A2
1,3	0,5	E12.1305.00 V	AMD3	X800 X400	2,3	1,0	E12.A1 E12.A2
1,3	0,6	E12.1306.00 V	AN0T	X800 X400	2,5	1,2	E12.A1 E12.A2

Bestellbeispiel // Order example: **E12.1304.00 V X800** (X800 = Schneidstoff // Grade)