

Stechen, schmale Sicherungsringnuten

Sicherungsringnuten, vgl. DIN 471/472 sowie DIN 983/984.

Grooving, Circlip Ring Grooves, slim widths

Circlip ring grooves comp. to DIN 471/472 and DIN 983/984.

Schnittwerte (Start) // Cutting parameters (start)	
f 0,04 mm/U	Vc Seite/Page 442

Passende Klemmhalter auf Seite // Suitable toolholders on page
372, 374, 375, 376, 377, 379

SP

Legende

HM

Legend

400

Scan QR-Code Oder besuchen Sie // Or Visit
www.simtek.info/cp/498

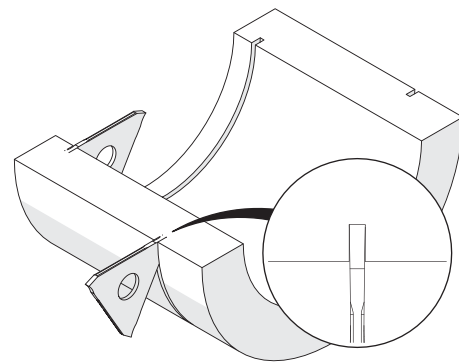
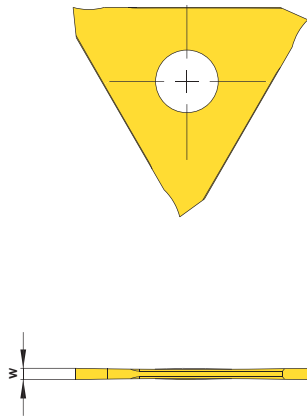

Abbildung zeigt / Drawing shows: E12.0100.00 H

Nutnenbreite Nominal width of groove mm	Artikelnummer Part number	Webcode www.simtek.com/webcode	Empfohlene Schneidstoffe Tagesaktuelle Verfügbarkeit und Preise finden Sie auf www.simtek.com/webcode						w +0,03 mm	Connectcode www.simtek.com/code
			P	K	M	N	S	H		
0,5	E12.0050.00 H	AM9A	X808	X408 X608	HX79	X508	X408	0,53	E12.A1	
0,6	E12.0060.00 H	ABMF	X808	X408 X608	HX79	X508	X408	0,63	E12.A1	
0,7	E12.0070.00 H	AHDK	X808	X408 X608	HX79	X508	X408	0,73	E12.A1	
0,8	E12.0080.00 H	AKMH	X808	X408 X608	HX79	X508	X408	0,83	E12.A1	
0,9	E12.0090.00 H	AA2Z	X808	X408 X608	HX79	X508	X408	0,93	E12.A1	
1,0	E12.0100.00 H	APFD	X808	X408 X608	HX79	X508	X408	1,03	E12.A1 E12.A2	

Bestellbeispiel // Order example: **E12.0100.00 H X808** (X808 = Schneidstoff // Grade)

simturn AX
simturn DX
simturn PX
simturn H2
simturn K2
simturn GX
simturn E3
simturn E12
simturn FX
simturn Decolletage
simturn OA
Index